

# WORKSHOP CALCULATION & SCIENCE

(NSQF)

(As per Revised Syllabus July 2022)

**Additive Manufacturing Technician  
(3D Printing)**



Directorate General of Training

**DIRECTORATE GENERAL OF TRAINING  
MINISTRY OF SKILL DEVELOPMENT & ENTREPRENEURSHIP  
GOVERNMENT OF INDIA**



**NATIONAL INSTRUCTIONAL  
MEDIA INSTITUTE, CHENNAI**

Post Box No. 3142, CTI Campus, Guindy, Chennai - 600 032

## **Workshop Calculation & Science**

### **Additive Manufacturing Technician (3D Printing) - NSQF**

**As per Revised Syllabus July 2022**

#### **Developed & Published by**



#### **National Instructional Media Institute**

Post Box No.3142

Guindy, Chennai - 600032

INDIA

Email: [chennai-nimi@nic.in](mailto:chennai-nimi@nic.in)

Website: [www.nimi.gov.in](http://www.nimi.gov.in)

Copyright © 2023 National Instructional Media Institute, Chennai

First Edition : December 2023

Copies: 1000

**Rs: 120/-**

All rights reserved.

No part of this publication can be reproduced or transmitted in any form or by any means, electronic or mechanical, including photocopy, recording or any information storage and retrieval system, without permission in writing from the National Instructional Media Institute, Chennai.

## FOREWORD

The Government of India has set an ambitious target of imparting skills one out of every four Indians, to help them secure jobs as part of the National Skills Development Policy. Industrial Training Institutes (ITIs) play a vital role in this process especially in terms of providing skilled manpower. Keeping this in mind, and for providing the current industry relevant skill training to Trainees, ITI syllabus has been recently updated with the help of comprising various stakeholder's viz. Industries, Entrepreneurs, Academicians and representatives from ITIs.

The National Instructional Media Institute (NIMI), Chennai, has now come up with instructional material to suit the revised curriculum for **Workshop Calculation & Science - Additive Manufacturing Technician (3D Printing)** NSQF (Revised 2022) under CTS will help the trainees to get an international equivalency standard where their skill proficiency and competency will be duly recognized across the globe and this will also increase the scope of recognition of prior learning. NSQF trainees will also get the opportunities to promote life long learning and skill development. I have no doubt that with NSQF the trainers and trainees of ITIs, and all stakeholders will derive maximum benefits from these IMPs and that NIMI's effort will go a long way in improving the quality of Vocational training in the country.

The Director General of Training, Executive Director & Staff of NIMI and members of Media Development Committee deserve appreciation for their contribution in bringing out this publication.

Jai Hind

**ATUL KUMAR TIWARI, I.A.S.**

Secretary  
Ministry of Skill Development & Entrepreneurship,  
Government of India.

December 2023  
New Delhi - 110 001

## PREFACE

The National Instructional Media Institute(NIMI) was set up at Chennai, by the Directorate General of Training, Ministry of skill Development and Entrepreneurship, Government of India, with the technical assistance from the Govt of the Federal Republic of Germany with the prime objective of developing and disseminating instructional Material for various trades as per prescribed syllabus and Craftsman Training Programme(CTS) under NSQF levels.

The Instructional materials are developed and produced in the form of Instructional Media Packages (IMPs), consisting of Trade Theory, Trade Practical, Test and Assignment Book, Instructor Guide. The above material will enable to achieve overall improvement in the standard of training in ITIs.

A national multi-skill programme called SKILL INDIA, was launched by the Government of India, through a Gazette Notification from the Ministry of Finance (Dept of Economic Affairs), Govt of India, dated 27th December 2013, with a view to create opportunities, space and scope for the development of talents of Indian Youth, and to develop those sectors under Skill Development.

The emphasis is to skill the Youth in such a manner to enable them to get employment and also improve Entrepreneurship by providing training, support and guidance for all occupation that were of traditional types. The training programme would be in the lines of International level, so that youths of our Country can get employed within the Country or Overseas employment. The **National Skill Qualification Framework (NSQF)**, anchored at the National Skill Development Agency(NSDA), is a Nationally Integrated Education and competency-based framework, to organize all qualifications according to a series of **levels of Knowledge, Skill and Aptitude**. Under NSQF the learner can acquire the Certification for Competency needed at any level through formal, non-formal or informal learning.

The **Workshop Calculation & Science - Additive Manufacturing Technician (3D Printing) NSQF (Revised 2022)** under CTS is one of the book developed by the core group members as per the NSQF syllabus.

The **Workshop Calculation & Science - Additive Manufacturing Technician (3D Printing) NSQF (Revised 2022)** under CTS as per NSQF is the outcome of the collective efforts of experts from Field Institutes of DGT, Champion ITI's for each of the Sectors, and also Media Development Committee (**MDC**) members and Staff of **NIMI**. NIMI wishes that the above material will fulfill to satisfy the long needs of the trainees and instructors and shall help the trainees for their Employability in Vocational Training.

NIMI would like to take this opportunity to convey sincere thanks to all the Members and Media Development Committee (MDC) members.

Chennai - 600 032

EXECUTIVE DIRECTOR

## ACKNOWLEDGEMENT

The National Instructional Media Institute (NIMI) sincerely acknowledge with thanks the co-operation and contribution of the following Media Developers to bring this IMP for the course **Workshop Calculation & Science - Additive Manufacturing Technician (3D Printing)** as per NSQF Revised 2022.

### MEDIA DEVELOPMENT COMMITTEE MEMBERS

Shri. M. Sangara pandian	-	Training Officer (Retd.) CTI, Govt. of India, Guindy, Chennai - 32.
Shri. G. Sathiamoorthy	-	Jr. Training Officer - SG (Retd.) Govt I.T.I, Trichy, DET - Tamilnadu.

### NIMI CO-ORDINATORS

Shri. Nirmalya Nath	-	Deputy General Manager, NIMI, Chennai - 32.
Shri. G. Michael Johny	-	Manager, NIMI, Chennai - 32.

NIMI records its appreciation of the **Data Entry, CAD, DTP Operators** for their excellent and devoted services in the process of development of this IMP.

NIMI also acknowledges with thanks, the efforts rendered by all other staff who have contributed for the development of this book.

## INTRODUCTION

The material has been divided into independent learning units, each consisting of a summary of the topic and an assignment part. The summary explains in a clear and easily understandable fashion the essence of the mathematical and scientific principles. This must not be treated as a replacement for the instructor's explanatory information to be imparted to the trainees in the classroom, which certainly will be more elaborate. The book should enable the trainees in grasping the essentials from the elaboration made by the instructor and will help them to solve independently the assignments of the respective chapters. It will also help them to solve the various problems, they may come across on the shop floor while doing their practical exercises.

The assignments are presented through 'Graphics' to ensure communications amongst the trainees. It also assists the trainees to determine the right approach to solve the problems. The required relevant data to solve the problems are provided adjacent to the graphics either by means of symbols or by means of words. The description of the symbols indicated in the problems has its reference in the relevant summaries.

At the end of the exercise wherever necessary assignments, problems are included for further practice.

**Time allotment - 1 Year : 38 Hrs**

Time allotment for each title of exercises has been given below. **Workshop Calculation & Science - Additive Manufacturing Technician (3D Printing) NSQF Revised Syllabus 2022.**

S.No	Title	Exercise No.	Time in Hrs
1	Unit, Fractions	1.1.01 - 1.1.07	4
2	Square root, Ratio and Proportions, Percentage	1.2.08 - 1.2.14	6
3	Material Science	1.3.15	6
4	Mass, Weight, Volume and Density	1.4.16	2
5	Heat & Temperature and Pressure	1.5.17	6
6	Mensuration	1.6.18 - 1.6.22	10
7	Trigonometry	1.7.23 - 1.7.25	4
		<b>Total</b>	<b><u>38 Hrs</u></b>

### LEARNING / ASSESSABLE OUTCOME

On completion of this book you shall be able to

- **Demonstrate basic mathematical concept and principles to perform practical operations.**
- **Understand and explain basic science in the field of study.**

## CONTENTS

Exercise No.	Title of the Exercise	Page No.
	<b>Unit, Fractions</b>	
1.1.01	Unit, Fractions - Classification of unit system	1
1.1.02	Unit, Fractions - Fundamental and Derived units F.P.S, C.G.S, M.K.S and SI units	2
1.1.03	Unit, Fractions - Measurement units and conversion	3
1.1.04	Unit, Fractions - Factors, HCF, LCM and problems	8
1.1.05	Unit, Fractions - Fractions - Addition, subtraction, multiplication & division	9
1.1.06	Unit, Fractions - Decimal fractions - Addition, subtraction, multiplication & division	12
1.1.07	Unit, Fractions - Solving problems by using calculator	15
	<b>Square root, Ratio and Proportions, Percentage</b>	
1.2.08	Square root, Ratio and Proportions, Percentage - Square and square root	19
1.2.09	Square root, Ratio and Proportions, Percentage - Simple problems using calculator	20
1.2.10	Square root, Ratio and Proportions, Percentage - Applications of pythagoras theorem and related problems	21
1.2.11	Square root, Ratio and Proportions, Percentage - Ratio and proportion	23
1.2.12	Square root, Ratio and Proportions, Percentage - Ratio and proportion - Direct and indirect proportions	25
1.2.13	Square root, Ratio and Proportions, Percentage - Percentage	28
1.2.14	Square root, Ratio and Proportions, Percentage - Changing percentage to decimal and fraction	30
	<b>Material Science</b>	
1.3.15	Types of plastics and its properties (warpage & shrinkage)	31
	<b>Mass, Weight, Volume and Density</b>	
1.4.16	Mass, Weight, Volume and Density - Mass, volume, density, weight and specific gravity	33
	<b>Heat &amp; Temperature and Pressure</b>	
1.5.17	Heat & Temperature and Pressure - Concept of heat and temperature, effects of heat, difference between heat and temperature, boiling point & melting point of different metals and non-metals	35
	<b>Mensuration</b>	
1.6.18	Mensuration - Area and perimeter of square, rectangle and parallelogram	37
1.6.19	Mensuration - Area and perimeter of triangles	41

<b>Exercise No.</b>	<b>Title of the Exercise</b>	<b>Page No.</b>
1.6.20	Mensuration - Area and perimeter of circle, semi-circle, circular ring, sector of circle, hexagon and ellipse	45
1.6.21	Mensuration - Surface area and volume of solids - Cube, cuboid, cylinder, sphere and hollow cylinder	51
1.6.22	Mensuration - Finding the lateral surface area, total surface area and capacity in litres of hexagonal, conical and cylindrical shaped vessels	56
	<b>Trigonometry</b>	
1.7.23	Trigonometry - Measurement of angles	58
1.7.24	Trigonometry - Trigonometrical ratios	60
1.7.25	Trigonometry - Trigonometrical tables	63



# SYLLABUS

**1 Year**

**Duration: 1 Year**

**Workshop Calculation & Science - Additive Manufacturing Technician (3D Printing)  
Revised syllabus July 2022 under CTS**

S.No.	Title	Time in Hrs
<b>I</b>	<b>Unit, Fractions</b> 1 Classification of Unit System 2 Fundamental and Derived Units F.P.S, C.G.S, M.K.S and SI Units 3 Measurement Units and Conversion 4 Factors, HCF, LCM and Problems 5 Fractions – Addition, Subtraction, Multiplication & Division 6 Decimal Fractions – Addition, Subtraction, Multiplication & Division 7 Solving Problems by using calculator	<b>4</b>
<b>II</b>	<b>Square root, Ratio and Proportions, Percentage</b> 1 Square and Square root 2 Simple problems using calculator 3 Applications of Pythagoras theorem and related problems 4 Ratio and Proportion 5 Ratio and Proportion - Direct and Indirect proportions 6 Percentage 7 Percentage - Changing percentage to decimal and fraction	<b>6</b>
<b>III</b>	<b>Material Science</b> 1 Types of plastics and its properties (warpage & shrinkage)	<b>6</b>
<b>IV</b>	<b>Mass, Weight, Volume, and Density</b> 1 Mass, volume, density, weight and specific gravity	<b>2</b>
<b>V</b>	<b>Heat &amp; Temperature and Pressure</b> 1 Concept of heat and temperature, effects of heat, difference between heat and temperature, boiling point & melting point of different metals and non-metals	<b>6</b>

S.No.	Title	Time in Hrs
VI	<b>Mensuration</b> 1 Area and perimeter of square, rectangle and parallelogram 2 Area and Perimeter of triangles 3 Area and Perimeter of circle, semi-circle, circular ring, sector of circle, hexagon and ellipse 4 Surface area and Volume of solids - cube, cuboid, cylinder, sphere and hollow cylinder 5 Finding the lateral surface area, total surface area and capacity in litres of hexagonal, conical and cylindrical shaped vessels	10
VII	<b>Trigonometry</b> 1 Measurement of angles 2 Trigonometrical ratios 3 Trigonometric tables	4
	<b>Total</b>	38

## Unit, Fractions - Classification of unit system

### Necessity

All physical quantities are to be measured in terms of standard quantities.

### Unit

A unit is defined as a standard or fixed quantity of one kind used to measure other quantities of the same kind.

### Classification

Fundamental units and derived units are the two classifications.

### Fundamental units

Units of basic quantities of length, mass and time.

### Derived units

Units which are derived from basic units and bear a constant relationship with the fundamental units. E.g. area, volume, pressure, force etc.

### Systems of units

- F.P.S system is the British system in which the basic units of length, mass and time are foot, pound and second respectively.
- C.G.S system is the metric system in which the basic units of length, mass and time are centimeter, gram and seconds respectively.
- M.K.S system is another metric system in which the basic units of length, mass and time are metre, kilogram and second respectively.
- S.I. units are referred to as Systems International units which is again of metric and the basic units, their names and symbols are as follows.

Fundamental units and derived units are the two classifications of units.

Length, mass and time are the fundamental units in all the systems (i.e) F.P.S, C.G.S, M.K.S and S.I. systems.

Example

**Length:** What is the length of copper wire in the roll, if the roll of copper wire weighs 8kg, the dia of wire is 0.9cm and the density is 8.9 gm/cm<sup>3</sup>?

### Solution

mass of copper wire in the roll = 8kg (or) 8000grams

Dia of copper wire in the roll = 0.9cm

Density of copper wire = 8.9 gm/cm<sup>3</sup>

Area of cross section of copper wire

$$= \frac{\pi d^2}{4} = \frac{\pi \times (0.9^2)}{4} = 0.636 \text{cm}^2$$

Volume of copper wire

$$= \frac{\text{Mass of copper wire}}{\text{Density of copper wire}} = \frac{8000 \text{grams}}{8.9 \text{ gm/cm}^3} = 898.88 \text{cm}^3$$

Length of copper wire

$$= \frac{\text{Volume of copper wire}}{\text{Area of cross section of copper wire}} = \frac{898.88 \text{cm}^3}{0.636 \text{cm}^2} = 1413.33 \text{ cm}$$

Length of copper wire = 1413cm.

**Time:** The S.I. unit of time, the second, is another base units of S.I., it is defined as the time interval occupied by a number of cycles of radiation from the calcium atom. The second is the same quantity in the S.I. in the British and in the U.S. systems of units.

### Fundamental units of F.P.S, C.G.S, M.K.S and S.I

S.No.	Basic quantity	British units		Metric units				International units	
		F.P.S	Symbol	C.G.S	Symbol	M.K.S	Symbol	S.I Units	Symbol
1	Length	Foot	ft	Centimetre	cm	Metre	m	Metre	m
2	Mass	Pound	lb	Gram	g	Kilogram	kg	Kilogram	Kg
3	Time	Second	s	Second	s	Second	s	Second	s
4	Current	Ampere	A	Ampere	A	Ampere	A	Ampere	A
5	Temperature	Fahrenheit	°F	Centigrade	°C	Centigrade	°C	Kelvin	K
6	Light intensity	Candela	Cd	Candela	Cd	Candela	Cd	Candela	Cd

## Unit, Fractions - Fundamental and Derived units F.P.S, C.G.S, M.K.S and SI units

Derived units of F.P.S, C.G.S, M.K.S and SI system

S.No	Physical quantity	British units		Metric units				International units	
		FPS	Symbol	CGS	Symbol	MKS	Symbol	SIUnits	Symbol
1	Area	Square foot	ft <sup>2</sup>	Square centimetre	cm <sup>2</sup>	Square metre	m <sup>2</sup>	Square metre	m <sup>2</sup>
2	Volume	Cubic foot	ft <sup>3</sup>	Cubic centimetre	cm <sup>3</sup>	Cubic metre	m <sup>3</sup>	Cubic metre	m <sup>3</sup>
3	Density	Pound per cubic foot	lb/ft <sup>3</sup>	Gram per cubic centimetre	g/cm <sup>3</sup>	Kilogram per cubic metre	kg/m <sup>3</sup>	Kilogram per cubic metre	Kg/m <sup>3</sup>
4	Speed	Foot per second	ft/s	Centimetre per second	cm/sec	Metre per second	m/sec	Metre per second	m/sec
5	Velocity (linear)	Foot per second	ft/s	Centimetre per second	cm/sec	Metre per second	m/sec	Metre per second	m/sec
6	Acceleration	Foot per square second	ft/s <sup>2</sup>	Centimetre per square second	cm/sec <sup>2</sup>	Metre per square second	m/sec <sup>2</sup>	Metre per square second	m/sec <sup>2</sup>
7	Retardation	Foot per square Second	ft/s <sup>2</sup>	Centimetre per square second	cm/sec <sup>2</sup>	Metre per square second	m/sec <sup>2</sup>	Metre square second	m/sec <sup>2</sup>
8	Angular velocity	Degree per second	Deg/sec	Radian per second	rad/sec	Radian per second	rad/sec	Radian per second	rad/sec
9	Mass	Pound (slug)	lb	Gram	g	Kilogram	kg	Kilogram	kg
10	Weight	Pound	lb	Gram	g	Kilogram weight	kg	Newton	N
11	Force	Pounds	lbf	dyne	dyn	Kilogram force	kgf	Newton	N(kgm/sec <sup>2</sup> )
12	Power	Foot pound per second	ft.lb/sec	Gram.centimetre/sec	g.cm/sec	kilogram metre per second	kg.m/sec	-	-
		Horse power	hp	Erg per second		watt	W	watt	W(J/sec)
13	Pressure, Stress	Pound per square inch	lb/in <sup>2</sup>	Gram per square centimetre	g/cm <sup>2</sup>	Kilogram per square metre	kg/m <sup>2</sup>	Newton per square metre	N/m <sup>2</sup>
14	Energy, Work	Foot.pound	ft.lb	Gram centimetre	g.cm	Kilogram metre	kg.m	joule	J(Nm)
15	Heat	British thermal unit	BTU	calorie	Cal	joule	J	joule	J(Nm)
16	Torque	Pound force foot	lbf.ft	Newton millimetre	N mm	Kilogram metre	kg.m	Newton metre	Nm
17	Temperature	Degree Fahrenheit	°F	Degree Centigrade	°C	Kelvin	K	Kelvin	K

## Unit, Fractions - Measurement units and conversion

## Units and abbreviations

Quantity	Units	Abbreviation of unit
Calorific value	kilojoules per kilogram	kJ/kg
Specific fuel consumption	kilogram per hour per newton	kg/hr/N
Length	millimetre, metre, kilometre	mm, m, km
Mass	kilogram, gram	kg, g
Time	seconds, minutes, hours	s, min, h
Speed	centimetre per second, metre per second kilometre per hour, miles per hour	cm/s, m/s km/h, mph
Acceleration	metre-per-square second	m/s <sup>2</sup>
Force	newtons, kilonewtons	N, kN
Moment	newton-metres	Nm
Work	joules	J
Power	horsepower, watts, kilowatts	Hp, W, kW
Pressure	newton per square metre kilonewton per square metre	N/m <sup>2</sup> kN/m <sup>2</sup>
Angle	radian	rad
Angular speed	radians per second radians-per-square second revolutions per minute revolutions per second	rad/s rad/s <sup>2</sup> Rpm rev/s

## Decimal multiples and parts of unit

Decimal power	Value	Prefixes	Symbol	Stands for
10 <sup>12</sup>	1000000000000	tera	T	billion times
10 <sup>9</sup>	1000000000	giga	G	thousand millintimes
10 <sup>6</sup>	1000000	mega	M	million times
10 <sup>3</sup>	1000	kilo	K	thousand times
10 <sup>2</sup>	100	hecto	h	hundred times
10 <sup>1</sup>	10	deca	da	ten times
10 <sup>-1</sup>	0.1	deci	d	tenth
10 <sup>-2</sup>	0.01	centi	c	hundredth
10 <sup>-3</sup>	0.001	milli	m	thousandth
10 <sup>-6</sup>	0.000001	micro	μ	millionth
10 <sup>-9</sup>	0.000000001	nano	n	thousand millionth
10 <sup>-12</sup>	0.000000000001	pico	p	billionth

**SI units and the British units:**

Quantity	SI unit → British unit	British unit → SI unit
Length	1 m = 3.281 ft 1 km = 0.621 mile	1 ft = 0.3048 m 1 mile = 1.609 km
Speed	1 m/s = 3.281 ft/s 1 km/h = 0.621 mph	1 ft/s = 0.305 m/s 1 mph = 1.61 km/h
Acceleration	1 m/s <sup>2</sup> = 3.281 ft/s <sup>2</sup>	1 ft/s <sup>2</sup> = 0.305 m/s <sup>2</sup>
Mass	1 kg = 2.205 lb	1 lb = 0.454 kg
Force	1 N = 0.225 lbf 1 MN	1 lbf = 4.448 N 1 million newtons
Torque	1 Nm = 0.738 lbf ft	1 lbf ft = 1.355 Nm
Pressure	1 N/m <sup>2</sup> = 0.000145 lbf/in <sup>2</sup> 1 Pa = 1 N/m <sup>2</sup> 1 bar = 14.5038 lbf/in <sup>2</sup>	1 lbf/in <sup>2</sup> = 6.896 kN/m <sup>2</sup> 1 lbf/in <sup>2</sup> = 6.895 kN/m <sup>2</sup>
Energy, work	1 J = 0.738 ft lbf 1 J = 0.239 calorie 1 kJ = 0.948 BTU (1 therm = 100 000 BTU) 1 kJ = 0.526 CHU	1 ft lbf = 1.355 J 1 calorie = 4.186 J 1 BTU = 1.055 kJ 1 CHU = 1.9 kJ
Power	1 kW = 1.34 hp	1 hp = 0.7457 kW
Fuel consumption	1 km/L = 2.82 mile/gallon	1 mpg = 0.354 km/L
Specific fuel consumption	1 kg/kWh = 1.65 lb/bhp h 1 litre/kWh = 1.575 pt/bhp h	1 lb/bhp h = 0.606 kg/kWh 1 pt/bhp h = 0.631 litre/kWh
Calorific value	1 kJ/kg = 0.43 BTU/lb 1 kJ/kg = 0.239 CHU/lb	1 BTU/lb = 2.326 kJ/kg 1 CHU/lb = 4.188 kJ/kg

## Prefixes for decimal multiples and submultiples

Use	
1 Megapascal	= 1 MPa = 1000000 Pa
1 Kilowatt	= 1 kW = 1000 W
1 Hectolitre	= 1 hL = 100 L
Decanewton	= 1 daN = 10 N
Decimetre	= 1 dm = 0.1 m
1 Centimetre	= 1 cm = 0.01 m
1 Millimetre	= 1 mm = 0.001 m
1 Micrometre	= 1 $\mu$ m = 0.000001 m

## Conversion factors

1 inch	= 25.4 mm
1 mm	= 0.03937 inch
1 metre	= 39.37 inch
1 micron	= 0.00003937"
1 kilometre	= 0.621 miles
1 pound	= 453.6 g
1 kg	= 2.205 lbs
1 metric ton	= 0.98 ton

## Units of physical quantities

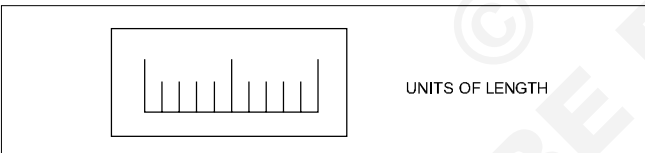

### Units of length

Micron	1 $\mu$	= 0.001 mm
Millimetre	1 mm	= 1000 $\mu$
Centimetre	1 cm	= 10 mm
Decimetre	1 dm	= 10 cm
Metre	1 m	= 10 dm
Kilometre	1 km	= 1000 m
Inch	1"	= 25.4 mm
Foot	1'	= 0.305 m
Yard	1 Yd	= 0.914 m
Nautical mile	1 NM	= 1852 m
Geographical mile	1	= 1855.4 m

## Units of area

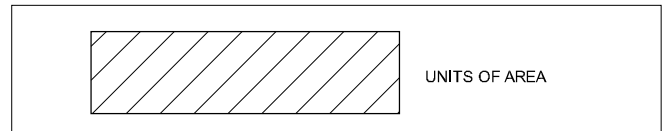

Square millimetre	1 mm <sup>2</sup>	
Square centimetre	1 cm <sup>2</sup>	= 100 mm <sup>2</sup>
Square decimetre	1 dm <sup>2</sup>	= 100 cm <sup>2</sup>
Square metre	1 m <sup>2</sup>	= 100 dm <sup>2</sup>
Are	1 a	= 100 m <sup>2</sup>
Hectare	1 ha	= 100 a
Square kilometre	1 km <sup>2</sup>	= 100 ha
Square inch	1 sq.in	= 6.45 cm <sup>2</sup>
Square foot	1 sq.ft	= 0.093 m <sup>2</sup>
Square yard	1 sq.yd	= 0.84 m <sup>2</sup>
Square metre	1 m <sup>2</sup>	= 10.76 ft <sup>2</sup>
Acre	1	= 40.5 a

1 Acre = 100 cent  
 1 Cent = 436 Sq. ft.  
 1 Ground = 2400 Sq.ft.

1 Hectare	= 2.47 acres
1 acre	= 0.4047 Hectare
1 Hectare	= 10000 sq. metre

## Units of weight

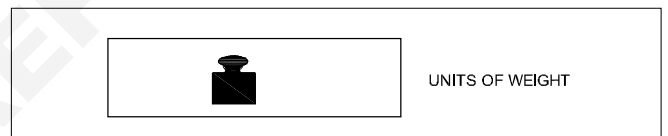

Milligram - force	1 mgf	
Gram-force	1 gf	= 1000 mgf
Kilogram-force	1 kgf	= 1000 gf
Tonne	1 t	= 1000 kgf
Ounce	1	= 28.35 gf
Pound	1 lbs	= 0.454 kgf
Long ton	1	= 1016 kgf
Short ton	1	= 907 kgf

## Units of volume and capacity

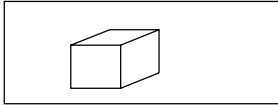

UNITS OF VOLUME AND CAPACITY

Cubic millimetre	1 mm <sup>3</sup>	
Cubic centimetre	1 cm <sup>3</sup>	= 1000 mm <sup>3</sup>
Cubic decimetre	1 dm <sup>3</sup>	= 1000 cm <sup>3</sup>
Cubic metre	1 m <sup>3</sup>	= 1000 dm <sup>3</sup>
Litre	1 l	= 1 dm <sup>3</sup>
Hectolitre	1 hl	= 100 l
Cubic inch	1 cu. in	= 16.387 cm <sup>3</sup>
Cubic foot	1 cu. ft	= 28317 cm <sup>3</sup>
Gallon (British)	1 gal	= 4.54 l
1 cubic metre	1 m <sup>3</sup>	= 1000 litres
1000 Cu.cm	1000 cm <sup>3</sup>	= 1 litre
1 cubic foot	1 ft <sup>3</sup>	= 6.25 Gallon
1 litre	1lt	= 0.22 Gallon

## Circular unit

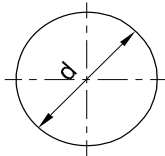

CIRCULAR OF UNIT

## Radian

Relationship between Radian and Degree

$$1 \text{ Radian} = \frac{180^\circ}{\pi}$$

$$180^\circ = \pi \text{ Radian};$$

$$1 \text{ Degree} = \frac{\pi}{180} \text{ Radian}$$

## Work



WORK

Kilogram-force	1 kgfm	= 9.80665 J
Metre	1 kgfm	= 9.80665 Ws
Joule	1 J	= 1 Nm
Watt-second	1 Ws	= 0.102 kgfm
Kilowatt hour	1 kWh	= 3.6 x 10 <sup>6</sup> J
		= 859.8456 kcal <sub>IT</sub>
I.T.Kilocalorie	1 kcal <sub>IT</sub>	= 426.kgfm

## Power



POWER

Kilogram-force metre/second

1 kgfm/s	= 9.80665 W
Kilowatt	1 kW = 1000 W = 1000 J/s
	= 102 kgfm/s (approx.)
Metric horse power	1 HP = 75 kgfm/s
	= 0.736 kW
1 Calorie	= 4.187J
I.T.Kilocalorie/hour	= 1 kcal <sub>IT/h</sub> = 1.163 W

## Pressure

Pascal	1 Pa	= 1 N/m <sup>2</sup>	1 atm	= 101325 Pa
Bar	1 bar = 10N/cm <sup>2</sup>	= 100000 Pa–Torr	1 torr	= $\frac{101325}{760} \approx 133.32 \text{ pa}$
Atmosphere	1 atm	= 1 kgf/cm <sup>2</sup>	1 kgf/cm <sup>2</sup>	= 735.6 mm of mercury

## TEMPERATURE

Scale	Freezing point	Boiling point
Centigrade (°C)	0°C	100°C
Fahrenheit (°F)	32°F	212°F
Kelvin (K)	273K	373K
Reaumur (°R)	0°R	80°R

TEMPERATURE



$$\frac{^\circ\text{R}}{80} = \frac{^\circ\text{C}}{100} = \frac{\text{K} - 273}{100} = \frac{^\circ\text{F} - 32}{180}$$



## FORCE

<b>Force</b>	In C.G.S. System : Force (Dyne) = Mass (gm) X Acceleration (cm/sec <sup>2</sup> )
	In F.P.S. System : Force (Poundal) = Mass (lb) X Acceleration (ft./sec <sup>2</sup> )
	In M.K.S System : Force (Newton) = Mass (Kg) x Acceleration (mtr./sec <sup>2</sup> )
1 Dyne	= 1 gm x 1 cm/sec <sup>2</sup>
1 Poundal	= 1 lb x 1 ft/sec <sup>2</sup>
1 Newton	= 1 kg x 1 mtr/sec <sup>2</sup> = 10 <sup>5</sup> dynes
1gm weight	= 981 Dynes
1 lb weight	= 32 Poundals
1 kg weight	= 9.81 Newtons

## ELECTRICAL QUANTITIES

V	Electric potential	V	Volt	V(W/A)
E	Electromotive force	V	Volt	V(W/A)
I	Electric current	A	Ampere	A
R	Electric resistance	Ω	Ohm	Ω (V/A)
e	Specific resistance	Ω m	Ohm metre	Vm/A
G	Conductance	Ω <sup>-1</sup>	Siemens	S

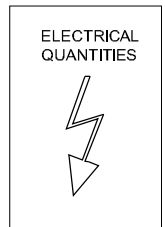

### Assignment - Answer the following question.

- Convert 320 kilometres into miles \_\_\_\_\_
- Convert 16 tons into kilograms \_\_\_\_\_
- Convert 40 inches into centimetres \_\_\_\_\_
- Convert 8 metres into feet \_\_\_\_\_
- Convert 2.5 gallons into litres \_\_\_\_\_
- Convert 5 litres into gallons \_\_\_\_\_
- 120°C = \_\_\_\_\_ °F.
- Expand the abbreviations of the following
  - N/m<sup>2</sup>
  - RPM
- Convert the following S.I. units as required.
  - Length
    - 3.4 m = \_\_\_\_\_ mm
    - 10.2 km = \_\_\_\_\_ mile
  - Mass
    - 650 g = \_\_\_\_\_ kg
    - 120 mg = \_\_\_\_\_ g
  - Force
    - 1.2 N = \_\_\_\_\_ kg
    - 25 kg = \_\_\_\_\_ N
  - Work, energy, amount of heat
    - 120 KJ = \_\_\_\_\_ J
    - 300 wh = \_\_\_\_\_ kwh
  - Power
    - 0.2 kW = \_\_\_\_\_ W
    - 350 W = \_\_\_\_\_ kW
  - Convert as required.
    - 5 N = \_\_\_\_\_ KN

Unit, Fractions - Factors, HCF, LCM and problems

Prime Numbers and whole Numbers

Factor

A factor is a small number which divides exactly into a bigger number.e.g.

To find the factors of 24, 72, 100 numbers

$$24 = 2 \times 2 \times 2 \times 3$$

$$72 = 2 \times 2 \times 2 \times 3 \times 3$$

$$100 = 2 \times 2 \times 5 \times 5$$

The numbers 2,3,5 are called factors.

Definition of a prime factor

Prime factor is a number which divides a prime number into factors.e.g.

$$57 = 3 \times 19$$

The numbers 3 and 19 are prime factors.

They are called as such, since 3 & 19 also belong to prime number category.

Definition of H.C.F

The Highest Common Factor

The H.C.F of a given group of numbers is the highest number which will exactly divide all the numbers of that group.e.g.

To find the H.C.F of the numbers 24, 72, 100

$$24 = 2 \times 2 \times 2 \times 3$$

$$72 = 2 \times 2 \times 2 \times 3 \times 3$$

$$100 = 2 \times 2 \times 5 \times 5$$

The factors common to all the three numbers are

$$2 \times 2 = 4. \text{ So HCF} = 4.$$

Definition of L.C.M

Lowest common multiple

The lowest common multiple of a group of numbers is the smallest number that will contain each number of the given group without a remainder.e.g.

- Factorise the following numbers

$$7,17,20,66,128$$

7,17 - These two belong to Prime numbers. Hence no factor except unity and itself.

$$\begin{array}{r|l} 2 & 20 \\ 2 & 10 \\ & 5 \end{array}$$

Factors of 20 =  $2 \times 2 \times 5$

$$\begin{array}{r|l} 2 & 66 \\ 3 & 33 \\ & 11 \end{array}$$

Factors of 66 =  $2 \times 3 \times 11$

$$\begin{array}{r|l} 2 & 128 \\ 2 & 64 \\ 2 & 32 \\ 2 & 16 \\ 2 & 8 \\ 2 & 4 \\ & 2 \end{array}$$

Factors of 128 =  $2 \times 2 \times 2 \times 2 \times 2 \times 2 \times 2$

- Select prime numbers from 3 to 29  
3,5,7,11,13,17,19,23,29
- Find the HCF of the following group of numbers HCF of 78, 128, 196

$$\begin{array}{r|l} 2 & 78 \\ 3 & 39 \\ & 13 \end{array}$$

$$78 = 2 \times 3 \times 13$$

$$\begin{array}{r|l} 2 & 128 \\ 2 & 64 \\ 2 & 32 \\ 2 & 16 \\ 2 & 8 \\ 2 & 4 \\ & 2 \end{array}$$

$$128 = 2 \times 2 \times 2 \times 2 \times 2 \times 2 \times 2$$

$$\begin{array}{r|l} 2 & 196 \\ 2 & 98 \\ & 49 \end{array}$$

$$196 = 2 \times 2 \times 49$$

$$\text{HCF} = 2$$

- Find LCM of 84,92,76

$$\text{LCM} = \begin{array}{r|l} 2 & 84, 92, 76 \\ 2 & 42, 46, 38 \\ 3 & 21, 23, 19 \\ & 7, 23, 19 \end{array}$$

$$\text{LCM} = 2 \times 2 \times 3 \times 7 \times 23 \times 19 = 36708$$

- To find out the LCM of 36, 108, 60

$$\begin{array}{r|l} 2 & 36, 108, 60 \\ 2 & 18, 54, 30 \\ 3 & 9, 27, 15 \\ 3 & 3, 9, 5 \\ & 1, 3, 5 \end{array}$$

LCM of the number

$$36, 108, 60 = 2 \times 2 \times 3 \times 3 \times 3 \times 5 = 540$$

The necessity of finding LCM and HCF arises in subtraction and addition of fractions.

Unit, Fractions - Fractions - Addition, subtraction, multiplication & division

**Description**

A minimal quantity that is not a whole number. For e.g. .

$\frac{1}{5}$  a vulgar fraction consists of a numerator and denominator.

**Numerator/Denominator**

The number above the line in a vulgar fraction showing how many of the parts indicated by the denominator are taken is the numerator. The total number of parts into which the whole quantity is divided and written below the line in a vulgar fraction is the denominator. e.g.

$$\frac{1}{4}, \frac{3}{4}, \frac{7}{12}$$

1,3,7 - numerators                      4,12 - denominators

**Fraction: Concept**

Every number can be represented as a fraction.e.g.

$1\frac{1}{4} = \frac{5}{4}$ , A full number can be represented as an apparent fraction.e.g. (Fig 1)

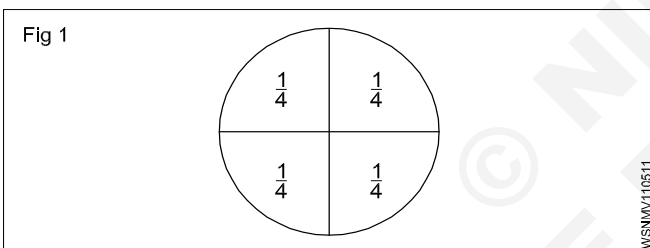

**Fraction: Value**

The value of a fraction remains the same if the numerator and denominator of the fraction are multiplied or divided by the same number.(Fig 2)

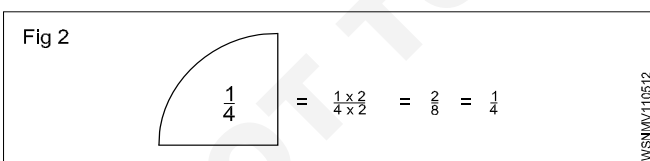

**Multiplication**

When fractions are to be multiplied, multiply all the numerators to get the numerator of the product and multiply all the denominators to form the denominator of the product. (Fig 3)

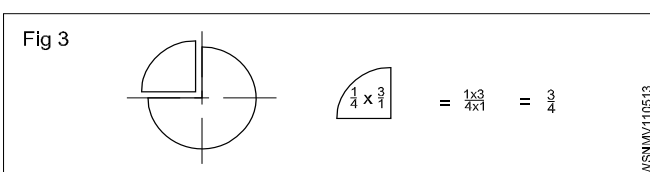

**Division**

When a fraction is divided by another fraction the dividend is multiplied by the reciprocal of the divisor. (Fig 4)

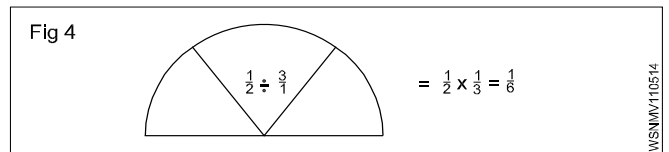

**Addition and Subtraction**

The denominators of the fractions should be the same when adding or subtracting the fractions. Unequal denominators must first be formed into a common denominator. It is the lowest common denominator and it is equal to the product of the most common prime numbers of the denominators of the fractions in question.(Fig 5)

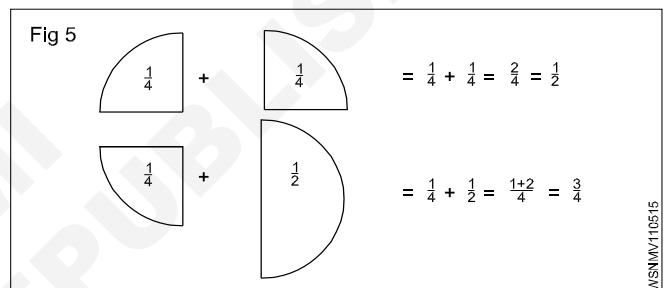

**Examples**

- Multiply  $\frac{3}{4}$  by  $\frac{2}{3}$ ,

$$\frac{3}{4} \times \frac{2}{3} = \frac{6}{12} = \frac{1}{2}$$

- Divide  $\frac{3}{8}$  by  $\frac{3}{4}$ ,

$$\frac{3}{8} \div \frac{3}{4} = \frac{3}{8} \times \frac{4}{3} = \frac{1}{2}$$

- Add  $\frac{3}{4}$  and  $\frac{2}{3}$ ,

$$\frac{3}{4} + \frac{2}{3} = \frac{9}{12} + \frac{8}{12} = \frac{17}{12} = 1\frac{5}{12}$$

- sub  $\frac{7}{16}$  from  $\frac{17}{32}$

$$\frac{17}{32} - \frac{7}{16} = \frac{17}{32} - \frac{14}{32} = \frac{(17 - 14)}{32} = \frac{3}{32}$$

## Types of fractions

- Proper fractions are less than unity. Improper fractions have their numerators greater than the denominators.
- A mixed number has a full number and a fraction.

## Addition of fraction

$$\text{Add } \frac{1}{2} + \frac{1}{8} + \frac{5}{12}$$

To add these fractions we have to find out L.C.M of denominators 2,8,12.

Find L.C.M of 2,8,12

Step 1 L.C.M

2	2,8,12
2	1,4,6
	1,2,3

Factors are 2,2,2,3

Hence L.C.M =  $2 \times 2 \times 2 \times 3 = 24$

Step 2

$$\begin{aligned} \frac{1}{2} + \frac{1}{8} + \frac{5}{12} &= \frac{12}{24} + \frac{3}{24} + \frac{10}{24} \\ &= \frac{12+3+10}{24} = \frac{25}{24} = 1\frac{1}{24} \end{aligned}$$

## Subtraction of fraction

$$\text{subtract } 9\frac{15}{32} \text{ from } 17\frac{9}{16} \text{ or } (17\frac{9}{16} - 9\frac{15}{32})$$

Step 1: Subtract whole number first  $17 - 9 = 8$

Step 2: L.C.M of 16,32 = 32

Since number 16 divides the number 32

$$\text{Subtracting fractions} = \frac{3}{32}$$

Adding with whole number from Step 1

$$\text{we get } 8 + \frac{3}{32} = 8\frac{3}{32}$$

## Common fractions

Problems with plus and minus sign

Example

$$\text{solve } 3\frac{3}{4} + 6\frac{7}{8} - 4\frac{5}{16} - \frac{9}{32}$$

Rule to be followed

- 1 Add all whole numbers
- 2 add all + Numbers
- 3 Add all - Numbers
- 4 Find L.C.M of all denominators

Solution

Step 1: Add whole numbers =  $3 + 6 - 4 = 5$

$$\text{Step 2: Add fractions} = \frac{3}{4} + \frac{7}{8} - \frac{5}{16} - \frac{9}{32}$$

L.C.M of 4,8,16,32 is 32

$$\begin{aligned} &\frac{24 + 28 - 10 - 9}{32} \\ &= \frac{52 - 19}{32} \\ &= \frac{33}{32} = 1\frac{1}{32} \end{aligned}$$

Step 3: Adding again with the whole number

$$\text{we get } 5 + 1\frac{3}{32} = 6\frac{3}{32}$$

## Examples

### Common fractions

- Multiply

$$\text{a } \frac{3}{8} \text{ by } \frac{4}{7} = \frac{3}{8} \times \frac{4}{7} = \frac{3}{14} \quad \text{b } \frac{2}{3} \times \frac{3}{4} \times \frac{5}{8} = \frac{5}{16}$$

- Division

$$\text{a } \frac{5}{16} \div \frac{5}{32} = \frac{5}{16} \times \frac{32}{5} = 2$$

$$\text{b } 4\frac{2}{3} \div 3\frac{1}{7} = \frac{14}{3} \div \frac{22}{7} = \frac{14}{3} \times \frac{7}{22} = \frac{49}{33} = 1\frac{16}{33}$$

- Addition

$$\frac{1}{2} + \frac{1}{4} + \frac{1}{8}$$

L.C.M = 2,4,8 = 8

$$\frac{1}{2} + \frac{1}{4} + \frac{1}{8} = \frac{4+2+1}{8} = \frac{7}{8}$$

- Subtraction

$$5\frac{1}{4} - 3\frac{3}{4} = 5 - 3 + \frac{1}{4} - \frac{3}{4}$$

$$= 2 + \frac{1}{4} - \frac{3}{4} = 2 - \frac{2}{4}$$

$$= \frac{9}{4} - \frac{3}{4} = \frac{9-3}{4}$$

$$= \frac{6}{4} = \frac{3}{2} = 1\frac{1}{2}$$

## Assignment

1 Convert the following into improper fractions.

a  $1\frac{2}{7} = \underline{\hspace{2cm}}$

b  $4\frac{3}{5} = \underline{\hspace{2cm}}$

c  $3\frac{3}{5} = \underline{\hspace{2cm}}$

2 Convert the following into mixed numbers.

a  $\frac{12}{11} = \underline{\hspace{2cm}}$

b  $\frac{36}{14} = \underline{\hspace{2cm}}$

c  $\frac{18}{10} = \underline{\hspace{2cm}}$

3 Place the missing numbers.

a  $\frac{11}{13} = \frac{x}{91}$  \_\_\_\_\_

b  $\frac{3}{5} = \frac{42}{x}$  \_\_\_\_\_

c  $\frac{9}{14} = \frac{x}{98}$  \_\_\_\_\_

4 Simplify.

a  $\frac{45}{60} = \underline{\hspace{2cm}}$

b  $\frac{8}{12} = \underline{\hspace{2cm}}$

5 Multiply.

a  $5 \times \frac{2}{3} = \underline{\hspace{2cm}}$

b  $\frac{3}{4} \times 2 = \underline{\hspace{2cm}}$

c  $\frac{3}{4} \times \frac{5}{6} = \underline{\hspace{2cm}}$

6 Divide

a  $\frac{1}{4} \div \frac{3}{4} = \underline{\hspace{2cm}}$

b  $6 \div \frac{3}{4} = \underline{\hspace{2cm}}$

c  $\frac{3}{4} \div \frac{2}{7} = \underline{\hspace{2cm}}$

7 Place the missing numbers.

a  $\frac{2}{3} = \frac{1}{12} \times \underline{\hspace{2cm}}$

b  $\frac{14}{24} = \frac{1}{12} \times \underline{\hspace{2cm}}$

c  $\frac{7}{8} = \frac{1}{12} \times \underline{\hspace{2cm}}$

8 Add the followings:

a  $\frac{3}{4} + \frac{7}{12} = \underline{\hspace{2cm}}$

b  $\frac{7}{8} + \frac{3}{4} = \underline{\hspace{2cm}}$

9 Subtract

a  $\frac{4}{5} - \frac{2}{5} = \underline{\hspace{2cm}}$

b  $\frac{5}{6} - \frac{3}{4} = \underline{\hspace{2cm}}$

10 Simplify

a  $2\frac{6}{7} - \frac{3}{8} - \frac{1}{3} - 1\frac{1}{16} = \underline{\hspace{2cm}}$

b  $2\frac{2}{7} - \frac{5}{6} + 8 = \underline{\hspace{2cm}}$

11 Express as improper fractions

a  $5\frac{3}{4}$

b  $3\frac{5}{64}$

c  $1\frac{5}{12}$

**Unit, Fractions - Decimal fractions - Addition, subtraction, multiplication & division**

**Description**

Decimal fraction is a fraction whose denominator is 10 or powers of 10 or multiples of 10 (i.e.) 10, 100, 1000, 10000 etc. Meaning of a decimal number:-

12.3256 means

$$(1 \times 10) + (2 \times 1) + \frac{3}{10} + \frac{2}{100} + \frac{5}{1000} + \frac{6}{10000}$$

**Representation**

The denominator is omitted. A decimal point is placed at different positions of the number corresponding to the magnitude of the denominator

Ex.  $\frac{5}{10} = 0.5, \frac{35}{100} = 0.35, \frac{127}{10000} = 0.0127, \frac{3648}{1000} = 3.648$

**Addition and subtraction**

Arrange the decimal fractions in a vertical order, placing the decimal point of each fraction to be added or subtracted, in succession one below the other, so that all the decimal points are arranged in a straight line. Add or subtract as you would do for a whole number and place the decimal point in the answer below the column of decimal points.

Decimal fractions less than 1 are written with a zero before the decimal point. Example:  $45/100 = 0.45$  (and not simply .45)

Add  $0.375 + 3.686$

$$\begin{array}{r} 0.375 \\ 3.686 \\ \hline 4.061 \end{array}$$

Subtract 18.72 from 22.61

$$\begin{array}{r} 22.61 \\ 18.72 \\ \hline 3.89 \end{array}$$

**Multiplication**

Ignore the decimal points and multiply as whole numbers. Find the total number of digits to the right of the decimal point. Insert the decimal point in the answer such that the number of digits to the right of the decimal point equals to the sum of the digits found to the right of the decimal points in the problem.

Multiply 2.5 by 1.25

=  $25 \times 125 = 3125$ . The sum of the figures to the right of decimal point is 3. Hence the answer is 3.125.

**Division**

Move the decimal point of the divisor to the right to make it a full number. Move the decimal point in the dividend to

the same number of places, adding zeroes if necessary. Then divide.

Divide 0.75 by 0.25

$$0.25 \overline{)0.75}$$

$$\frac{0.75}{0.25} \times \frac{100}{100} = \frac{75}{25}$$

$$25 \overline{)75} = 3$$

**Move the decimal point in the multiplicand to the right to one place if the multiplier is 10, and to two places if the multiplier is 100 and so on. When dividing by 10 move the decimal point one place to the left, and, if it is by 100, move them point by two places and so on.**

**Example**

Allowance allowing 3 mm for cutting off each pin, how many pins can be made from a 900 mm long bar and how much material will be left out?

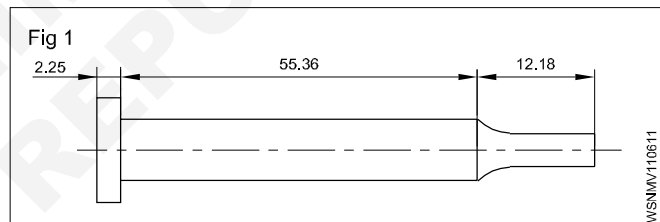

Total Length of pin =  $2.25 + 55.36 + 12.18$   
= 69.79 mm

Cutting allowance = 3 mm

Total Length = length of pin + cutting allowance  
=  $69.79 \text{ mm} + 3 \text{ mm}$   
= 72.79 mm

Length of the bar = 900 mm

No. of pins to be cut =  $\frac{900}{72.79} = 12.394$   
= 12 pins

Left out material = Total length - length of pin + cutting allowance  
=  $900 - 12 \times 69.79 + 12 \times 3$   
=  $900 - 837.48 + 36$   
=  $900 - 873.48$

Left out length = 26.52 mm

### Conversion of Decimals into fractions and vice-versa

- Convert decimal into fractions

#### Example

Convert 0.375 to a fraction

Now place 1 under the decimal point followed by as many zeros as there are numbers

$$0.375 = \frac{375}{1000} = \frac{15}{40} = \frac{3}{8}$$

$$0.375 = \frac{3}{8}$$

- Convert fraction into decimal

#### Example

- Convert  $\frac{9}{16}$  to a decimal

Proceed to divide  $\frac{9}{16}$  in the normal way of division but put zeros (as required) after the number 9 (Numerator)

$$\begin{array}{r} 0.5625 \\ 16 \overline{)90000} \\ \underline{80} \phantom{00} \\ 100 \phantom{00} \\ \underline{96} \phantom{00} \\ 40 \phantom{00} \\ \underline{32} \phantom{00} \\ 80 \phantom{00} \\ \underline{80} \phantom{00} \\ 0 \end{array}$$

$$\frac{9}{16} = 0.5625$$

### Recurring decimals

While converting from fraction to decimals, some fractions can be divided exactly into a decimal. In some fractions the quotient will not stop. It will continue and keep recurring. These are called recurring decimals.

#### Examples

- convert  $\frac{1}{3}, \frac{2}{3}, \frac{1}{7}$

a  $\frac{1}{3} = \frac{10000}{3} = 0.3333$  – Recurring

b  $\frac{2}{3} = \frac{20000}{3} = 0.666$  – Recurring

c  $\left( \frac{1}{7} = \frac{10000}{7} = 0.142857142 \right)$  – Recurring

### Method of writing approximations in decimals

$$1.73556 = 1.7356 \text{ Correct to 4 decimal places}$$

$$5.7343 = 5.734 \text{ Correct to 3 decimal places}$$

$$0.9345 = 0.94 \text{ Correct to 2 decimal places}$$

### Multiplication and division by 10, 100, 1000

Multiplying decimals by 10

A decimal fraction can be multiplied by 10, 100, 1000 and so on by moving the decimal point to the right by as many places as there are zeros in the multiplier.

- $4.645 \times 10 = 46.45$  (one place)
- $4.645 \times 100 = 464.5$  (two places)
- $4.645 \times 1000 = 4645$  (three places)

Dividing decimals by 10

A decimal fraction can be divided by 10, 100, 1000 and so on, by moving the decimal point to the left by as many places as required in the divisor by putting zeros

#### Examples

- $3.732 \div 10 = 0.3732$  (one place)
- $3.732 \div 100 = 0.03732$  (two places)
- $3.732 \div 1000 = 0.003732$  (three places)

#### Examples

- Rewrite the following number as a fraction

$$453.273$$

$$= (4 \times 100) + (5 \times 10) + (3 \times 1) + \frac{2}{10} + \frac{7}{100} + \frac{3}{1000}$$

$$= 453 \frac{273}{1000}$$

- Write the representation of decimal places in the given number 0.386

3 - 1st decimal place — 0.3

8 - 2nd decimal place — 0.08

6 - 3rd decimal place — 0.006

- Write approximations in the following decimals to 3 places.

a  $6.9453 \longrightarrow 6.945$

b  $8.7456 \longrightarrow 8.746$

- Convert fraction to decimal

$$\frac{21}{24} = \frac{7}{8} = 0.875$$

- Convert decimal to fraction

$$0.0625 = \frac{625}{10000} = \frac{5}{80} = \frac{1}{16}$$

## Assignment

---

- 1 Write down the following decimal numbers in the expanded form.
- a 514.726  
b 902.524
- 2 Write the following decimal numbers from the expansion.
- a  $500 + 70 + 5 + \frac{3}{10} + \frac{2}{100} + \frac{9}{1000}$   
b  $200 + 9 + \frac{1}{10} + \frac{3}{100} + \frac{5}{1000}$
- 3 Convert the following decimals into fractions in the simplest form.
- a 0.72  
b 5.45  
c 3.64  
d 2.05
- 4 Convert the following fraction into decimals
- a  $\frac{3}{5}$   
b  $\frac{10}{4}$   
c  $24 \frac{54}{1000}$   
d  $\frac{12}{25}$   
e  $\frac{8}{25}$   
f  $1 \frac{3}{25}$
- 5 Addition of decimals
- a  $4.56 + 32.075 + 256.6245 + 15.0358$   
b  $462.492 + 725.526 + 309.345 + 626.602$
- 6 Subtract the following decimals
- a  $612.5200 - 9.6479$   
b  $573.9246 - 215.6000$
- 7 Add and subtract the following
- a  $56.725 + 48.258 - 32.564$   
b  $16.45 + 124.56 + 62.7 - 3.243$
- 8 Multiply the following
- a By 10,100,1000  
i  $3.754 \times 10$   
ii  $8.964 \times 100$   
iii  $2.3786 \times 1000$   
iv  $0.005 \times 1000$
- b By whole numbers  
i  $8.4 \times 7$   
ii  $56.72 \times 8$
- c By another decimal figure (use calculator)  
i  $15.64 \times 7.68$   
ii  $2.642 \times 1.562$
- 9 Divide the following
- a  $\frac{62.5}{25}$   
b  $\frac{64.56}{10}$   
c  $\frac{0.42}{100}$   
d  $\frac{48.356}{1000}$
- 10 Division
- a  $\frac{16.8}{1.2}$   
b  $\frac{1.54}{1.1}$
- 11 Change the fraction into a decimal
- i  $1 \frac{5}{8}$   
ii  $\frac{12}{25}$
- 12 Find the value  
 $20.5 \times 40 \div 10.25 + 18.50$



Unit, Fractions - Solving problems by using calculator

A pocket calculator allows to spend less time in doing tedious calculations. A simple pocket calculator enables to do the arithmetical calculations of addition, subtraction, multiplication and division, while a scientific type of calculator can be used for scientific and technical calculations also.

No special training is required to use a calculator. But it is suggested that a careful study of the operation manual of the type of the calculator is essential to become familiar with its capabilities. A calculator does not think and do. It is left to the operator to understand the problem, interpret the information and key it into the calculator correctly.

Constructional Details (Fig 1)

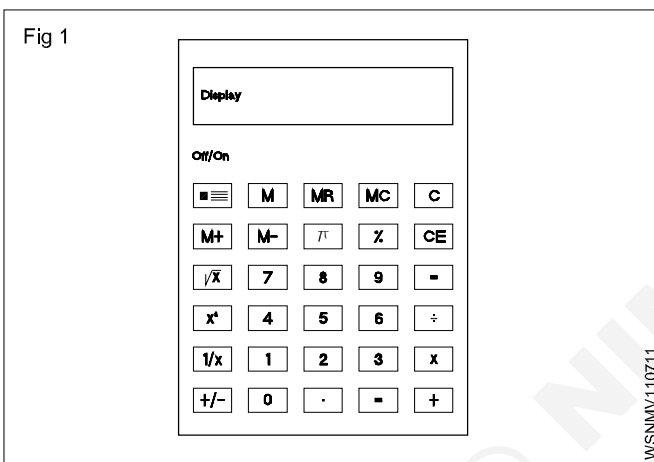

The key board is divided into five clear and easily recognizable areas and the display.

• Data entry keys

The entry keys are from 0 .....to 9

and a key for the decimal point . .

• Clearing keys

These keys have the letter 'C'

C CLR Clear totally

CE Clear entry only

CM , MC Clear memory

- + Addition key
- Subtraction key
- x Multiplication key
- ÷ Division key
- = Equals key to display the result

• Function keys

- π Pi key
- $\sqrt{x}$  Square root key
- % Percentage key
- +/- Sign change key
- $x^2$  Square key
- $\frac{1}{x}$  Reciprocal key

• Memory keys

- M Store the display number
- M+ The displayed value is added to the memory
- M- The displayed value is subtracted from the memory
- MR RCL The stored value is recalled on to the display

Further functional keys included in Scientific calculators are as shown in Fig 2.

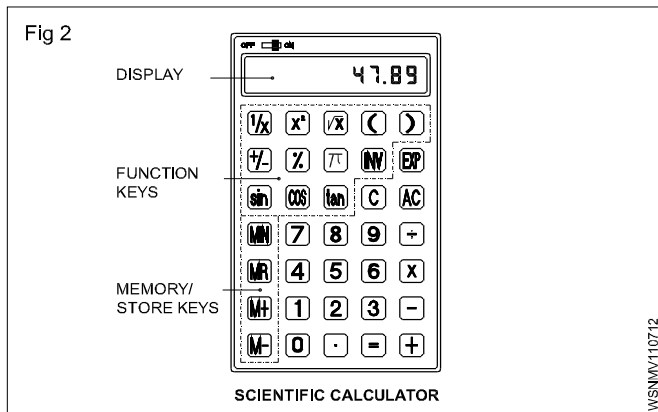

$\sin$   $\cos$   $\tan$   $($   $)$  For trigonometric functions and for brackets

$\text{Exp}$  Exponent key

$\text{INV}$  Some of the keys have coloured lettering above or below them. To use a function in coloured lettering, press INV key. INV will appear on the display. Then press the key that the coloured lettering identifies. INV will disappear from the display.

$\log$  ,  $\text{INV}$   $10^x$  to obtain the logarithm of the displayed number and the antilogarithm of the displayed value.

$\text{INV}$   $\text{R-P}$  to convert displayed rectangular coordinates into polar coordinates.

$\text{INV}$   $\text{P-R}$  to convert displayed polar coordinates into rectangular coordinates.

#### • The display

The display shows the input data, interim results and answers to the calculations.

**The arrangement of the areas can differ from one make to another. Keying in of the numbers is done via an internationally agreed upon set of ten keys in the order that the numbers are written.**

Rules and Examples:

- **Addition:** Example  $18.2 + 5.7$

Sequence	Input	Display
Input of the 1st term of the sum	$18.2$	18.2
Press + key	$+$	18.2
Input 2nd term of the sum. the first term goes into the register	$5.7$	5.7
Press the = key	$=$	23.9

- **Subtraction:** Example  $128.8 - 92.9$

Sequence	Input	Display
Enter the subtrahend	$128.8$	128.8
Press - key	$-$	128.8
Enter the minuend. The subtrahend goes into the register	$92.9$	92.9
Press the = key	$=$	35.9

- **Multiplication:** Example  $0.47 \times 2.47$

Sequence	Input	Display
Enter multiplicand	$0.47$	0.47
Press x key	$\times$	0.47
Enter multiplier, multiplicand goes to register	$2.47$	2.47
Press = key	$=$	1.1609

- **Division:** Example  $18.5/2.5$

Sequence	Input	Display
Enter the dividend	$18.5$	18.5
Press ÷ Key	$\div$	18.5
Enter the divisor goes to the register	$2.5$	2.5
Press = key	$=$	7.4

- **Multiplication & Division:**  
Example : 2.5 x 7.2 / 4.8 x 1.25

Sequence	Input	Display
Enter 2.5	2 . 5	2.5
Press x key	x	2.5
Enter 7.2	7 . 2	7.2
Press ÷ key	÷	18
Enter Open bracket	(	
Enter 4.8	4 . 8	4.8
Press x key	x	4.8
Enter 1.25	1 . 2 5	1.25
Enter Close bracket	)	6
Press = key	=	3.0

- Store in memory Example (2+6) (4+3)

Sequence	Input	Display
Workout for the first bracket	2	2
	+	2
	6	6
	=	8
Store the first result in	STO , M	8
x	or M+	
Workout for the 2nd bracket	4	4
	+	4
	3	3
	=	7
Press x key	x	7
Recall memory	RCL or MR	8
Press = key	=	56

- **Percentage:** Example 12% of 1500

Sequence	Input	Display
Enter 1500	1 5 0 0	1500
Press x key	x	1500
Enter 12	1 2	12
Press INV %	INV %	12
Press = key	=	180

- **Square root:** Example  $\sqrt{2} + \sqrt{3 \times 5}$

Sequence	Input	Display
Enter 2	2	2
Press $\sqrt{a}$ key	$\sqrt{a}$	1.414
Press + key	+	1.414
Press bracket key	(	1.414
Enter 3	3	3
Press $\sqrt{a}$ key	$\sqrt{a}$	1.732
Press x key	x	1.732
Enter 5	5	5
Press $\sqrt{a}$ key	$\sqrt{a}$	2.236
Press bracket close key	)	3.873
Press = key	=	5.2871969
	2 $\sqrt{a}$ + ( 3 $\sqrt{a}$ x 5 $\sqrt{a}$ ) =	5.2871969

$$\sqrt{2} + \sqrt{3 \times 5} = 5.287$$

- **Common logarithm:** Example log 1.23

Sequence	Input	Display
	1 . 2 3 log =	0.0899051

- **Power:** Example  $123 + 30^2$

Sequence	Input	Display
	1 2 3 + 3 0 INV X <sup>2</sup> =	1023

- Before starting the calculations be sure to press the 'ON' key and confirm that '0' is shown on the display.
- Do not touch the inside portion of the calculator. Avoid hard knocks and unduly hard pressing of the keys.
- Maintain and use the calculator in between the two extreme temperatures of 0° and 40° C.

- Never use volatile fluids such as lacquer, thinner, benzene while cleaning the unit.
- Take special care not to damage the unit by bending or dropping.
- Do not carry the calculator in your hip pocket.

## Assignment

1 Using calculator solve the following

- $625 + 3467 + 20 + 341 + 6278 =$  \_\_\_\_\_
- $367.4 + 805 + 0.7 + 7.86 + 13.49 =$  \_\_\_\_\_
- $0.043 + 1.065 + 13.0 + 34.76 + 42.1 =$  \_\_\_\_\_
- $47160 + 1368.4 + 0.1 + 1.6901 + 134.267 =$  \_\_\_\_\_

2 Using calculator simplify the following

- $24367 - 4385 =$  \_\_\_\_\_
- $9.643 - 0.7983 =$  \_\_\_\_\_
- $4382.01 - 381.3401 =$  \_\_\_\_\_
- $693.42 - 0.0254 =$  \_\_\_\_\_

3 Using calculator find the values of the following

- $23 \times 87 =$  \_\_\_\_\_
- $1376 \times 0.81 =$  \_\_\_\_\_
- $678 \times 243 =$  \_\_\_\_\_
- $0.75 \times 0.24 =$  \_\_\_\_\_

4 Using calculator solve the following

- $22434 \div 3 =$  \_\_\_\_\_
- $4131 \div 243 =$  \_\_\_\_\_
- $469890 \div 230 =$  \_\_\_\_\_
- $3.026 \div 0.89 =$  \_\_\_\_\_

5 Solve the following

- $\frac{1170 \times 537.5}{13 \times 215} =$  \_\_\_\_\_
- $\frac{28.2 \times 18 \times 3500}{1000 \times 3 \times 0.8} =$  \_\_\_\_\_

6 Solve the following

- $\frac{(634 + 128) \times (384 - 0.52)}{8 \times 0.3} =$  \_\_\_\_\_

$$b \frac{(389 - 12.2) \times (842 - 0.05 - 2.6)}{(3.89 - 0.021) \times (28.1 + 17.04)} =$$

7

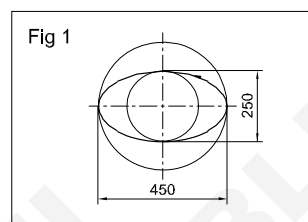

$$2a = 450 \text{ mm (major axis)}$$

$$2b = 250 \text{ mm (minor axis)}$$

Perimeter of the ellipse

$$A = \text{_____ metre}^2$$

$$\text{Hint } A = \pi \times a \times b \text{ unit}^2$$

8

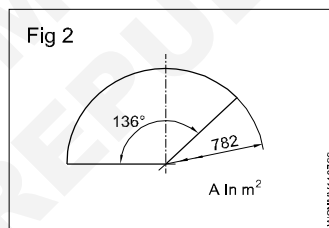

$$\phi = 782 \text{ mm}$$

$$\alpha = 136^\circ$$

Area of the sector

$$A = \text{_____}$$

$$\text{Hint } A = \frac{\pi \times d^2}{4} \times \frac{\alpha}{360^\circ}$$

9

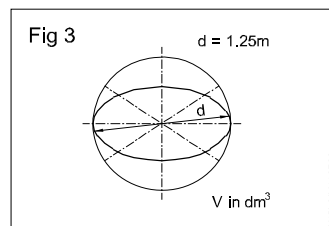

$$d = 1.25 \text{ metre}$$

$$V = \text{_____ dm}^3$$

Volume of sphere

$$\text{Hint } V = \frac{4}{3} \pi r^3$$

10

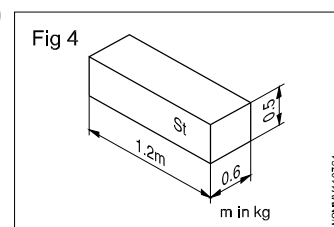

$$L = 1.2 \text{ metres}$$

$$B = 0.6 \text{ metre}$$

$$H = 0.5 \text{ metre}$$

' $\rho$ ' (rho) density of steel

$$= 7.85 \text{ kg/dm}^3$$

$$m = \text{_____ kg}$$

$$\text{(mass 'm' = V x } \rho \text{)}$$

Square root, Ratio and Proportions, Percentage - Square and square root

- a basic number
- 2 exponent

√ radial sign indicating the square root.

√a<sup>2</sup> square root of 'a' square

a<sup>2</sup> radicand

**Square number**

The square of a number is the number multiplied by itself.

Basic number x basic number = Square number

a x a = a<sup>2</sup>

4 x 4 = 4<sup>2</sup> = 16

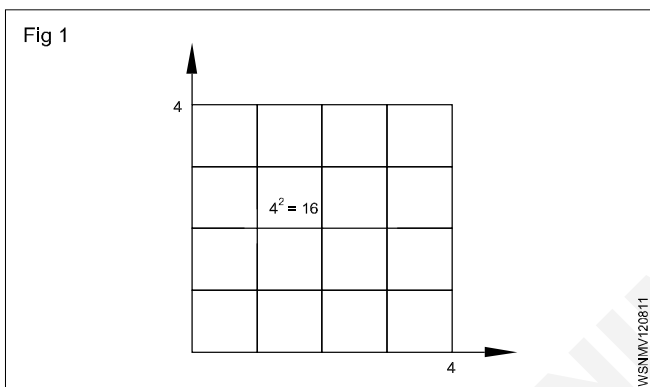

**Splitting up (Fig 2)**

A square area can be split up into sub-areas. The largest square of 36 is made up of a large square 16, a small square 4 and two rectangles 8 each.

Large square 4 x 4 = 16                      a<sup>2</sup>

Two rectangles 2 x 4 x 2 = 16              2ab

Small square 2 x 2 = 4                      b<sup>2</sup>

Sum of sub-areas = 36 = a<sup>2</sup> + 2ab + b<sup>2</sup>

√36 = √a<sup>2</sup> + 2ab + b<sup>2</sup>

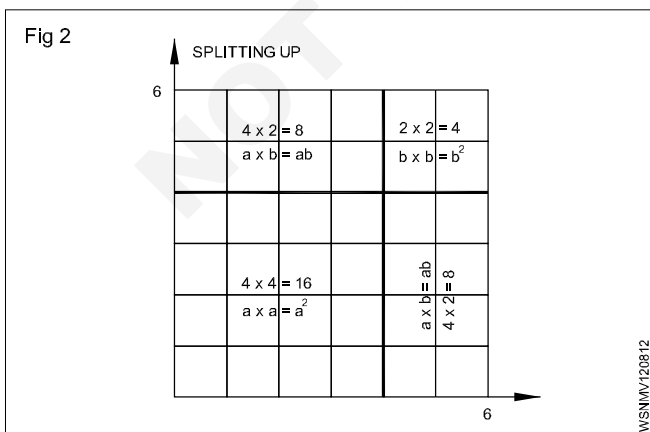

Result: In order to find the square root, we split up the square numbers.

**Extracting the square root procedure**

- Starting from the decimal point form groups of two figures towards right and left. Indicate by a prime symbol. √4624.00
- Find the root of the first group, calculate the difference, bring down the next group.
- Multiply the root by 2 and divide the partial radicand.
- Enter the number thus calculated in the divisor for the multiplication.

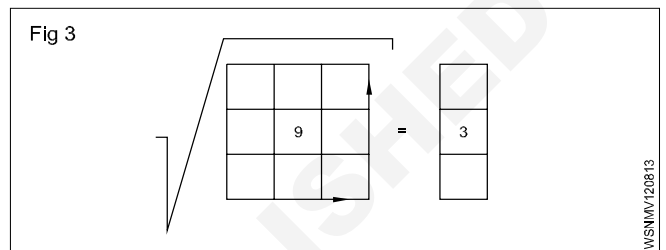

If there is a remainder, repeat the procedure.

$$\begin{array}{r}
 68 \\
 6 \overline{) 46,24} \\
 \underline{36} \phantom{00} \\
 1024 \\
 \underline{1024} \\
 0
 \end{array}$$

√4624 = 68

**Basic number x basic number = Square**  
 √Square number = basic number

**Example**

The cross-section of a rivet is 3.46 cm<sup>2</sup>. Calculate the diameter of the hole.

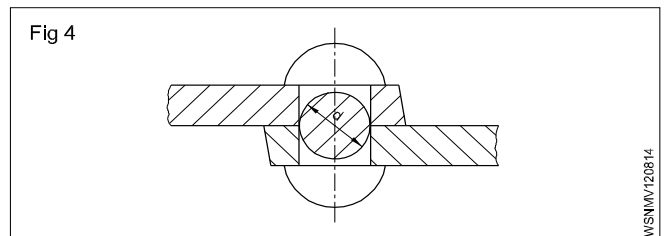

Rivet cross-section is the hole cross-section.

To find 'd',

Given that Area = 3.46 cm<sup>2</sup>

Area = 0.785 x d<sup>2</sup> (formula)

3.46 cm<sup>2</sup> = d<sup>2</sup> x 0.785

$$d^2 = \frac{3.46 \text{ cm}^2}{0.785}$$

$$d = \sqrt{\frac{3.46}{0.785}} \text{ cm}$$

d = 2.1 cm (or) 21mm

Square root, Ratio and Proportions, Percentage - Simple problems using calculator

1 a  $\sqrt{2916} =$  \_\_\_\_\_.

b  $\sqrt{45796} =$  \_\_\_\_\_.

c  $\sqrt{8.2944} =$  \_\_\_\_\_.

d  $\sqrt{63.845} =$  \_\_\_\_\_.

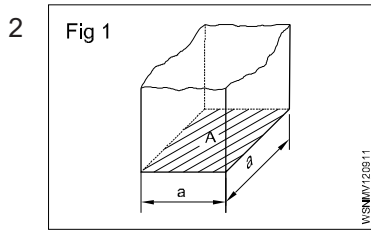

A = 2025 mm<sup>2</sup>  
a = \_\_\_\_\_ mm

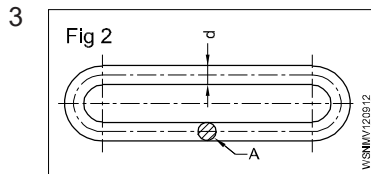

A = 176.715 mm<sup>2</sup>  
d = \_\_\_\_\_ mm

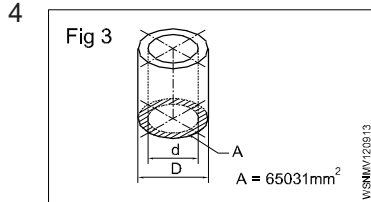

A = 65031 mm<sup>2</sup>  
d = 140 mm  
D = \_\_\_\_\_ mm

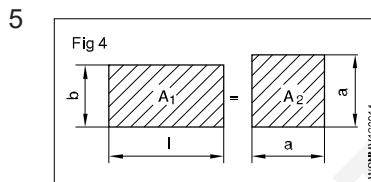

l = 58 cm  
b = 45 cm  
A<sub>1</sub> = A<sub>2</sub>  
a = \_\_\_\_\_ cm

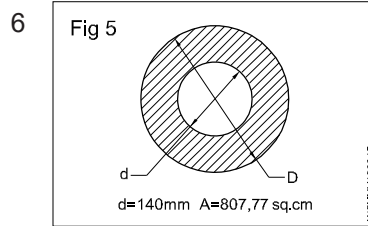

A = 807.77 cm<sup>2</sup>  
d = 140 mm  
D = \_\_\_\_\_ mm

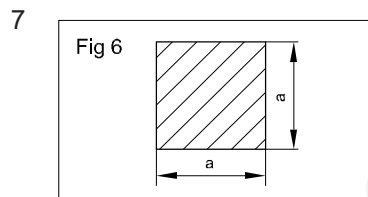

a x a = 543169 mm<sup>2</sup>  
a = \_\_\_\_\_ mm

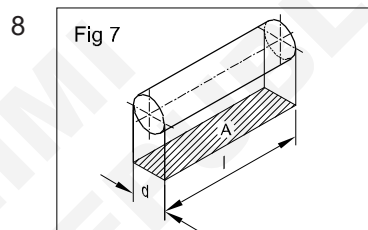

d : l = 1:1.5  
A = 73.5 mm<sup>2</sup>  
d = \_\_\_\_\_ mm

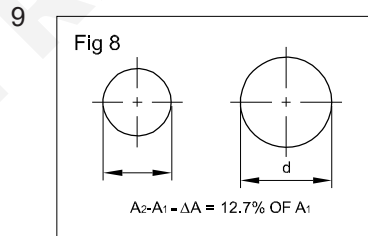

increase in area  
A = 12.7%  
A = 360 mm<sup>2</sup>  
d = \_\_\_\_\_ mm  
(d = diameter after the increase in area)

Square root, Ratio and Proportions, Percentage - Applications of pythagoras theorem and related problems

Applications of Pythagoras Theorem

Some of the applications of the Pythagoras theorem are; (Fig 1)

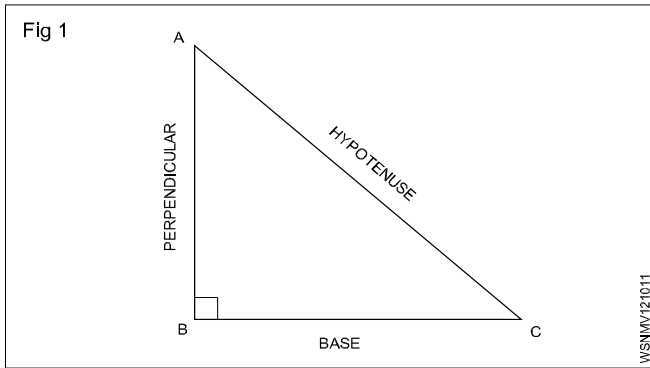

- 1 The Pythagoras theorem is commonly used to find the lengths of sides of a right-angled triangle.
- 2 It is used to find the length of the diagonal of a square.
- 3 Pythagoras theorem is used in trigonometry to find the trigonometric ratios like sin, cos, tan, cosec, sec and cot.
- 4 Pythagoras theorem is used in security cameras for face recognition.
- 5 Architects use the technique of the Pythagoras theorem for engineering and construction fields.
- 6 The Pythagoras theorem is applied in surveying the mountains.
- 7 It is also used in navigation to find the shortest route.
- 8 By using the Pythagoras theorem, we can derive the formula for base, perpendicular and hypotenuse.
- 9 Painters use ladders to paint on high buildings with the help of the Pythagoras theorem.
- 10 Pythagoras theorem is used to calculate the steepness of slopes of hills or mountains.
- 11 The converse of the Pythagoras theorem is used to check whether a triangle is a right triangle or not.

Application of pythagoras theorem in real life

Pythagoras theorem states that

"In a right-angled triangle, the square of the hypotenuse side is equal to the sum of squares of the other two sides".

- 1 The sides of this triangle have been named Perpendicular, Base and Hypotenuse.
- 2 The hypotenuse is the longest side, as it is opposite to the angle 90°.

- 3 The sides of a right triangle (say AB, BC and CA) which have positive integer values, when squared, are put into an equation, also called a Pythagorean triplet.
- 4 To calculate the length of staircase required to reach a first floor.
- 5 To find the length of the longest item can be kept in your room.
- 6 To find the steepness of the hills or mountains.
- 7 To find the original height of a tree broken due to heavy rain and lying on itself
- 8 To determine heights and measurements in the construction sites.

Examples

- 1 What is the side AC if AB = 15 cm, BC = 25 cm.

$$AC^2 = AB^2 + BC^2$$

$$= 15^2 + 25^2$$

$$= 225 + 625 = 850$$

$$AC = \sqrt{850} = 29.155 \text{ cm}$$

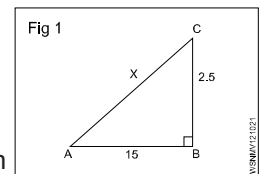

- 2 What is the side BC if AB = 10 cm, AC = 30 cm.

$$AC^2 = AB^2 + BC^2$$

$$30^2 = 10^2 + BC^2$$

$$900 = 100 + BC^2$$

$$BC^2 = 900 - 100 = 800$$

$$BC = 28.284 \text{ cm}$$

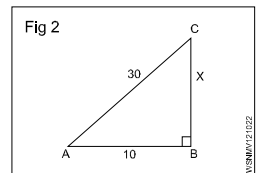

- 3 What is the side AB if BC = 20 cm, AC = 35 cm.

$$AC^2 = AB^2 + BC^2$$

$$35^2 = AB^2 + 20^2$$

$$1225 = AB^2 + 400$$

$$AB^2 = 1225 - 400 = 825$$

$$AB = 28.72 \text{ cm}$$

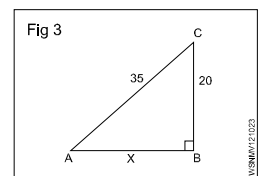

- 4 What is the value of side BC if AB = 8 cm, AC = 24 cm.

$$AC^2 = AB^2 + BC^2$$

$$24^2 = 8^2 + BC^2$$

$$576 = 64 + BC^2$$

$$BC^2 = 576 - 64 = 512$$

$$BC = \sqrt{512} = 22.63 \text{ cm}$$

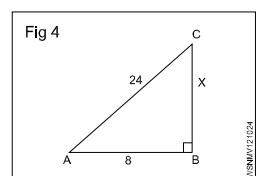

- 5 What is the value side AC if AB = 6.45 cm, BC = 8.52 cm.

$$\begin{aligned} AC^2 &= AB^2 + BC^2 \\ AC^2 &= 6.45^2 + 8.52^2 \\ AC^2 &= 41.60 + 72.59 \\ &= 114.19 \end{aligned}$$

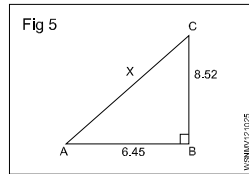

$$AC = \sqrt{114.19} = 10.69 \text{ cm}$$

- 6 What is the value of side AB if BC = 3.26 cm, AC = 8.24 cm.

$$\begin{aligned} AC^2 &= AB^2 + BC^2 \\ 8.24^2 &= AB^2 + 3.26^2 \\ 67.9 &= AB^2 + 10.63 \\ AB^2 &= 67.9 - 10.63 \\ &= 57.27 \end{aligned}$$

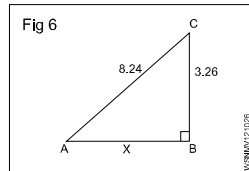

$$AB = \sqrt{57.27} = 7.57 \text{ cm}$$

- 7 What is the value of side AB if AC = 12.5 cm, BC = 8.5 cm.

$$\begin{aligned} AC^2 &= AB^2 + BC^2 \\ 12.5^2 &= AB^2 + 8.5^2 \\ 156.25 &= AB^2 + 72.25 \\ AB^2 &= 156.25 - 72.25 \\ &= 84 \end{aligned}$$

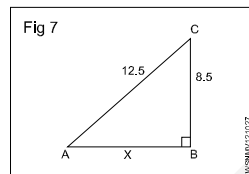

$$AB = \sqrt{84} = 9.17 \text{ cm}$$

- 8 A ladder of 12.5 metre long is placed with upper end against a wall. The lower end being 7.5 metres from the wall. What height is the upper end above the ground.

$$\begin{aligned} AC^2 &= AB^2 + BC^2 \\ BC^2 &= AC^2 - AB^2 \\ BC^2 &= x^2 \\ AC^2 &= AB^2 + BC^2 \\ 12.5^2 &= x^2 + 7.5^2 \end{aligned}$$

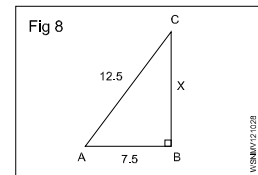

$$\begin{aligned} x^2 &= (12.5)^2 - (7.5)^2 \\ &= (12.5 + 7.5)(12.5 - 7.5)^2 \\ &= 20 \times 5 \\ &= \sqrt{100} = 10 \\ x &= 10 \text{ m} \end{aligned}$$

- 9 What is the value of AB.

$$\begin{aligned} AC^2 &= AB^2 + BC^2 \\ AB^2 &= AC^2 - BC^2 \\ AB^2 &= x^2 \\ AC^2 &= AB^2 + BC^2 \\ 10^2 &= x^2 + 6^2 \\ x^2 &= 10^2 - 6^2 \\ &= 100 - 36 = 64 \\ x &= \sqrt{64} \\ &= 8 \\ AB &= 8 \end{aligned}$$

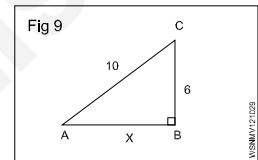

## Assignment

- 1 What is the value of side AB, in a right angled triangle of side AC = 10 cm and BC = 5 cm.
- 2 What is the value of side AC, in a right angled triangle of side AB = 6.5 cm and BC = 4.5 cm.
- 3 What is the value of side BC, in a right angled triangle of side AC = 14.5 cm and AB = 10.5 cm.
- 4 What is the value of side AC, in a right angled triangle of side AB = 7 cm and BC = 5 cm.
- 5 What is the value of side BC, in a right angled triangle of side AC = 13.25 cm and AB = 8.75 cm.



Square root, Ratio and Proportions, Percentage - Ratio and proportion

Ratio

Introduction

It is the relation between two quantities of the same kind and is expressed as a fraction.

Expression

a, b two quantities of the same kind.  $\frac{a}{b}$  or a:b or a ÷ b or

a in b is the ratio.

Ratio is always reduced to the lowest terms.

Example

$$7:14 = \frac{7}{14} = \frac{1}{2} = 1:2$$

Proportion

It is the equality between the ratios, a : b is a ratio and c : d is another ratio. Both ratios are equal. Then

$$a : b :: c : d \text{ or } \frac{a}{b} = \frac{c}{d}$$

Example

$$250 : 2000 :: 1 : 8$$

Proportion fundamentals

If  $\frac{a}{b} = \frac{c}{d}$  then

- $ad = bc$

- $\frac{a}{c} = \frac{b}{d}$

- $\frac{b}{a} = \frac{d}{c}$

- $\frac{a+b}{b} = \frac{c+d}{c}$  and  $\frac{a+b}{a} = \frac{c+d}{d}$

- $\frac{a-b}{b} = \frac{c-d}{d}$

- $\frac{a+b}{b+d} = \frac{a}{c} = \frac{c}{d}$

$$3:4::6:8 \text{ or } \frac{3}{4} = \frac{6}{8}$$

- $3 \times 8 = 6 \times 4$

- $\frac{3}{6} = \frac{4}{8}$

- $\frac{4}{3} = \frac{8}{6}$

- $\frac{3+4}{4} = \frac{6+8}{8}$

- $\frac{3-4}{4} = \frac{6-8}{8}$

- $\frac{3+6}{4+8} = \frac{9}{12} = \frac{3}{4}$

Ratio - relation of two quantities of the same kind.  
Proportion - equality between two ratios.

Example

- A steel plate of 800 x 1400 mm is to be drawn to a scale of 1:20. What will be the lengths in the Fig 1.

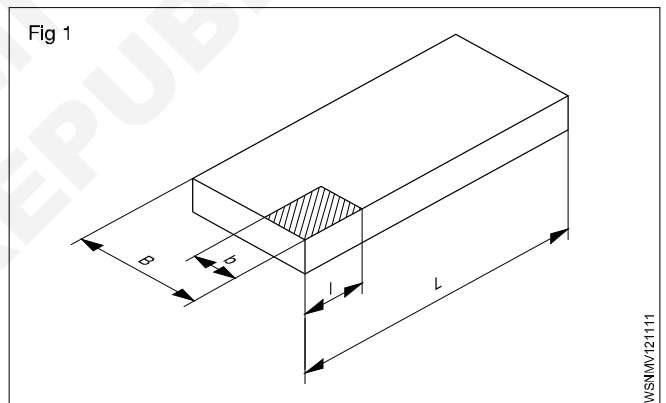

The reduction ratio is  $\frac{1}{20}$ .

B is reduced from 800 =  $800 \times \frac{1}{20} = 40$  mm.

L is reduced from 1400 =  $1400 \times \frac{1}{20} = 70$  mm.

- Find the number of teeth of the larger gear in the gear transmission shown in the Fig 2.

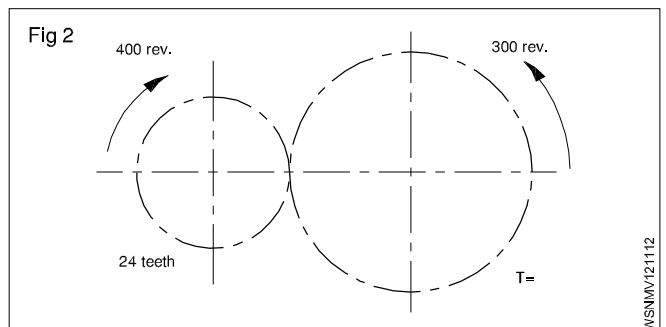

Speed ratio = 400 : 300

Teeth ratio = 24:T

$$\frac{400}{300} = \frac{T}{24}$$

$$\therefore T = \frac{24 \times 400}{300} = 32 \text{ Teeth}$$

Find the ratio of A:B:C

If A:B= 2:3 and B:C=4:5

$$A:B = 2:3$$

$$B:C = 4:5$$

$$A:B = 8 : 12 \text{ (Ratio 2:3 multiply by 4)}$$

$$B:C = 12:15 \text{ (Ratio 4:5 multiply by 3)}$$

$$\therefore A:B:C = 8:12:15$$

## Assignment

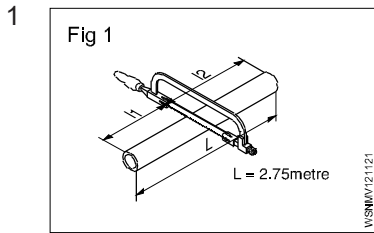

$$l_1 : l_2 = 2:3$$

$$L = 2.75 \text{ metres}$$

$$l_1 = \text{_____ metres}$$

$$l_2 = \text{_____ metres}$$

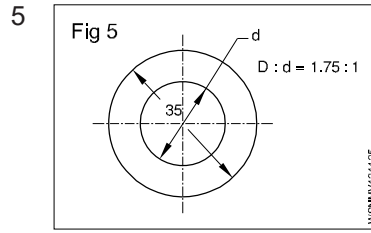

$$D : d = 1.75 : 1$$

$$D = 35 \text{ mm}$$

$$d = \text{_____ mm}$$

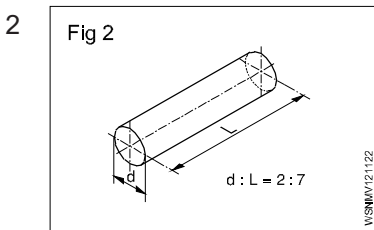

$$d : L \text{ of shaft} = 2:7$$

$$d = 40 \text{ mm}$$

$$L = \text{_____ mm}$$

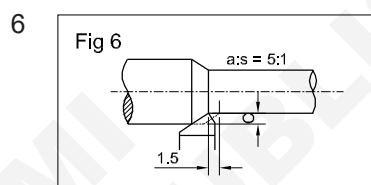

$$a : s = 5 : 1$$

$$s = 1.5 \text{ mm}$$

$$a = \text{_____ mm}$$

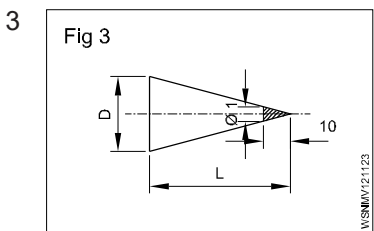

$$D : L = 1 : 10$$

$$L = 150 \text{ mm}$$

$$D = \text{_____ mm}$$

$$7 \quad A:B=9:12$$

$$B:C=8:10$$

$$\text{Then } A:B:C = \text{_____}$$

$$8 \quad A:B=5:6$$

$$B:C=3:4$$

$$\text{Then } A:B:C = \text{_____}$$

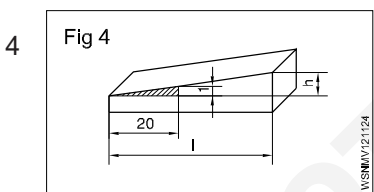

$$\frac{\Delta h}{l} = \frac{1}{20}$$

$$l = 140 \text{ mm}$$

$$\Delta h = \text{_____ mm}$$

$$9 \quad A:55=9:11$$

$$A = \text{_____}$$

$$10 \quad 15:9.3=40:x$$

$$x = \text{_____}$$

Square root, Ratio and Proportions, Percentage - Ratio and Proportion - Direct and indirect proportions

**Proportion**

**Description**

It is the equality between the ratios, a:b is a ratio and c:d is another ratio. Both ratios are equal. Then

$a : b :: c : d$  or e.g.  $250 : 2000 :: 1 : 8$

**Rule of three**

A three step calculation

statement

single

multiple.

**Direct proportion**

The more in one the more in the other - An increase in one denomination produces an increase in the other. (Fig 1)

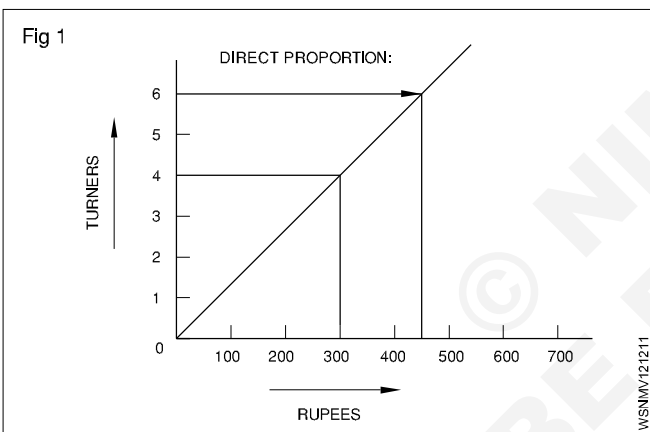

**Examples**

- 4 turners earn 300 Rupees. How much will 6 Turners earn?

Statement

4 turners = 300 Rupees

Single

1 Turner = 75 Rupees

Multiple

6 Turners =  $6 \times 75 = 450$  Rupees

- One vehicle consumes 30 litres of petrol per day how much petrol is used by 6 Vehicles operating under similar condition.

One vehicle uses petrol = 30 litres per day.

Then six vehicles will use = 6 Times as much

=  $6 \times 30 = 180$  litres/day.

- 4 vehicles consumes 120 gallons of petrol per day how much petrol will be used by 12 vehicles operating under the same condition.

4 vehicles use 120 gallons per day

1 Vehicle will use  $\frac{120}{4} = 30$  gallons/day

12 vehicles will use  $12 \times 30 = 360$  gallons/day

**This example is called simple proportion because only two quantities were used and the day is common for both ratios.**

- If 2 litres of petrol costs Rs 60. Find the cost of 50 litres.

Quantity of Petrol	Cost of Petrol
--------------------	----------------

2 litres	Rs.60
----------	-------

50 litres	$x$
-----------	-----

1 litre petrol =  $\frac{60}{2} = \text{Rs.}30$

50 litres petrol =  $30 \times 50 = \text{Rs } 1500$

- A 150mm dia gear meshes with 50mm dia gear. If the larger gear has 30 teeth. How many teeth will have the smaller gear have?

Gear dia	No. of Teeth
----------	--------------

150 mm	30
--------	----

50 mm	$x$
-------	-----

$x = \frac{50}{150} \times 30 = 10$  teeth.

- A mechanic assembles 7 machines in  $2\frac{1}{2}$  days. How long will it take time to assemble 70 machines at the same rate.

Machines	Days
----------	------

7	$2\frac{1}{2}$
---	----------------

70	$x$
----	-----

$x = \frac{70 \times 2.5}{7} = 25$  days

Assemble for 70 machines will take 25 days.

- A roll of wire weighs 1.24 kg from this roll a piece of 3.7cm long is cut and it is found to weigh 2.93 gm. What is the length of the wire in the roll?

Weight of wire	Length of wire
----------------	----------------

2.93 gm	3.7 cm
---------	--------

1.24 kg (1240 gm)	$x$
-------------------	-----

$$x = \frac{1240}{2.93} \times 3.7 = 1566 \text{ cm}$$

Length of wire = 1566 cm.

### Indirect or inverse proportion

The more in one the lesser other - Increase in one quantity will produce a decrease in the other. (Fig 2)

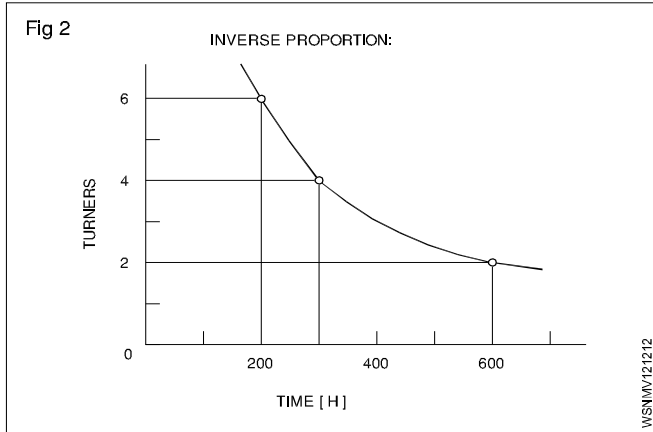

### Example

- 1 4 turners finish a job in 300 hours. How much time will 6 turners take to do the same job?

Solution procedure in three steps:

Statement 4 turners taken = 300 hours

The time will reduce if 6 turners to do the same job. Therefore this is inverse proportion.

Multiple fraction  $\frac{4 \text{ Turners}}{6 \text{ Turners}} \times 300 \text{ hours}$

6 Turners = 200 hours

Result - The more the less.

- 2 8 workman take 6 days to complete a job. How many days it will take for 4 workman to complete the same job?

Workman	Days
8	6
4	x

$$x = \frac{8}{4} \times 6 = 12 \text{ days}$$

4 workers complete the work = 12 days.

- 3 5 men working on a job finished it in 32 days. Find out in how many days 8 men will finish the same job?

Men	Days
5	32
8	x

$$x = \frac{5 \times 32}{8} = 4 \times 5 = 20 \text{ days}$$

8 men will complete the job = 20 days.

- 4 An engine running at 150 rpm drives a shaft by pulley diameter is 55cm and that of the driven shaft pulley is 33 cm. Find the speed of the shaft?

Dia of pulley	Rpm of shaft
55 cm	150
33 cm	x

$$x = \frac{55 \times 150}{33} = 250 \text{ rpm.}$$

Speed of the 33cm diameter will run 250 rpm.

- 5 A pulley of 80 cm diameter is rotating at 100 rpm and drives another pulley of 40 cm diameter. Find the rpm of driven pulley. If slip is 2.5% find the rpm?

Dia of pulley	Rpm of pulley
80 cm	100
40 cm	x

40 cm diameter = 200 rpm.

Slip is 2.5% = 195 rpm.

### Problems involving both

#### Example

2 turners need 3 days to produce 20 pieces. How long will it take for 6 turners to produce 30 such pieces?

Statement

2 turners, 20 pieces = 3 days

6 turners, 30 pieces = how many days.

First step (Fig 3)

Statement 2 turners for 20 pieces = 3 days

1 turner for 20 pieces =  $3 \times 2 = 6$  days

Multiple 6 turners for 20 pieces =  $\frac{6}{6} = 1$  day

Statement 6 turners for 20 pieces = 1 day

Single 6 turners for 1 piece =  $\frac{1}{20}$  days

Multiple 6 turners for 30 pieces =  $\frac{1}{20} \times 30 = 1.5$  days

**Inverse proportion - More the less.**

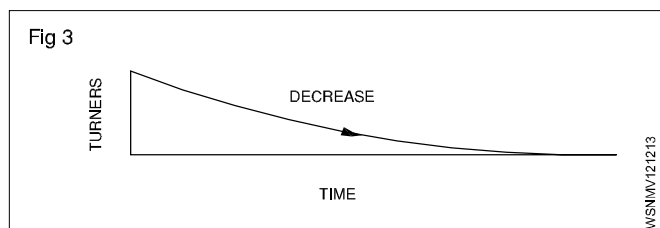

Second step (Fig 4)

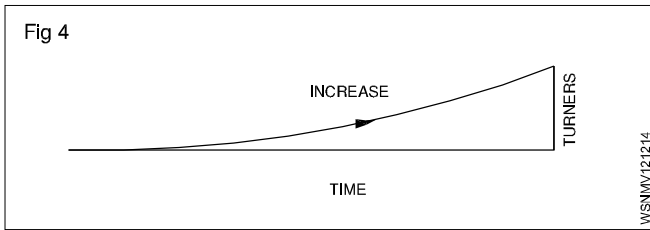

**Direct proportion - More the more.**

**Solve the problem by first writing the statement and proceed to single and then to the multiple according to the type of proportion that is involved.**

**Introduction**

Proportional fundamentals, as applicable to motor vehicle calculations are discussed below.

**Simple Proportion**

- Proportion

This is an equality between two ratios

**Compound and Inverse proportions**

- Compound proportions

**Example**

5 Fitter take 21 days to complete overhauling of 6 vehicles how long 7 Fitters will take to over haul 8 vehicles (Assume time of overhauling each vehicle is constant)

In this both direct and indirect proportions are used.

- 1 Fitter will overhauling 1 vehicle in days (shorter time).
- Quantities (No. of days) are taken in last as that is the answer required in this case.

Fitters	Vehicle	Days
5	6	21
7	8	x

$$\left(\frac{21 \times 5}{6 \times 7} \times 8\right) = 20 \text{ days}$$

**Ans:** 7 Fitters will overhaul 8 vehicles in 20 days.

**Inverse proportion**

Some times proportions are taken inversely.

**Examples**

- If one water pump fills the fuel tank in 12 minutes, two pumps will take half the time taken.

**The time should not be doubled.**

- 2 pumps will take 30 minutes to fill up a tank how long will 6 similar pumps take this to fill this tank.

Pump	Time
2	30
6	x

**Ans:** Time taken by 6 pumps =  $\frac{30 \times 2}{6} = 10 \text{ minutes}$

**Assignment**

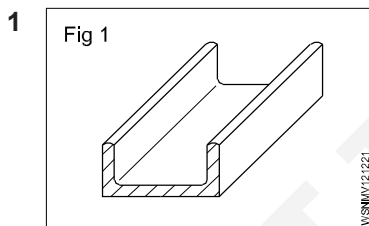

Length = 6.1 metre  
Weight = 32 kgf  
Weight of 1 metre of the same channel = \_\_\_\_\_ kgf

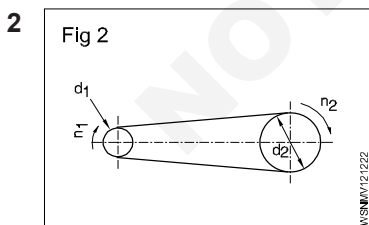

$d_1 = 120 \text{ mm}$   
 $d_2 = 720 \text{ mm}$   
 $n_1 = 1200 \text{ rpm}$   
 $n_2 = \text{_____ rpm}$

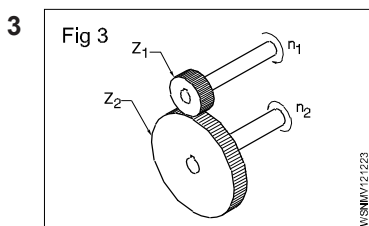

$Z_1 = 42 \text{ T}$   
 $n_2 = 96 \text{ rpm}$   
 $n_1 = 224 \text{ rpm}$   
 $Z_2 = \text{_____ T}$

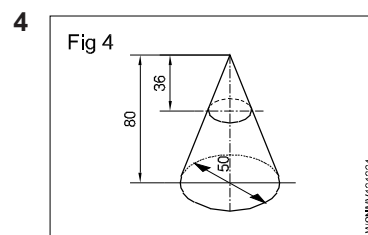

$D = 50 \text{ mm}$   
 $H = 80 \text{ mm}$   
 $h = 36 \text{ mm}$   
 $d = \text{_____ mm}$

- 5 If a mechanic assembles 8 machines in 3 days, how long he will take to assemble 60 machines.
- 6 In an auto shop the grinding wheel makes 1000 rpm and the driven pulley is 200 mm dia. If the driving pulley is 150 mm dia. Find out the rpm of the driving pulley.
- 7 In a gearing of a vehicle the following facts are found. A 180 mm dia of gear meshes with 60mm dia gear. If the bigger gear makes 60 rpm. What will be the rpm of smaller gear.
- 8 A vehicular job is completed by 5 mechanics in 4 days. If only 3 mechanics are available, in how many days the work can be completed.

Square root, Ratio and Proportions, Percentage - Percentage

Percentage

Percentage is a kind of fraction whose denominator is always 100. The symbol for percent is %, written after the number. e.g. 16%.

Ex.  $\frac{16}{100} = 0.16$

In decimal form, it is 0.16. Percentage calculation also involves rule of three. The statement (the given data), for unit, and then to multiple which is for calculating the answer. (Fig 1)

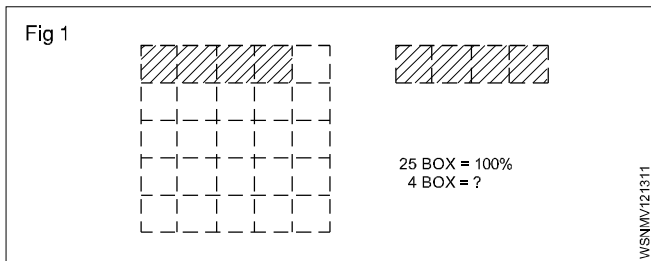

Example

The amount of total raw sheet metal to make a door was 3.6 metre<sup>2</sup> and wastage was 0.18 metre<sup>2</sup>. Calculate the % of wastage. (Fig 2)

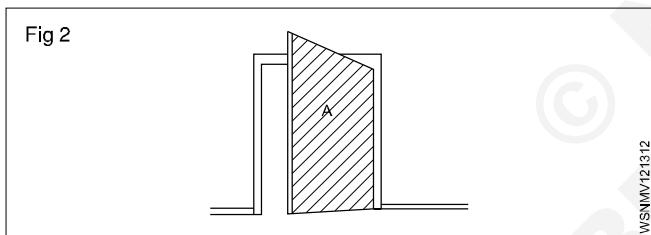

Solution procedure in three steps.

Statement:

Area of door (A) = 3.6 m<sup>2</sup> = 100 %.

Wastage = 0.18 m<sup>2</sup>

Single:  $\frac{100}{3.6} \times 1 \text{ m}^2$

Multiple: for 0.18 m<sup>2</sup> =  $\frac{100}{3.6} \times 0.18$ .

Wastage = 5%.

Analyse the given data and proceed to arrive at the answer through the unit.

Example

A fitter receives a take-home salary of 984.50 rupees.

If the deduction amounts to 24%, what is his total salary? (Fig 3)

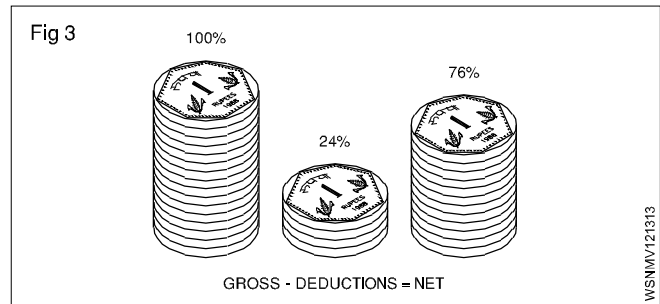

Total pay 100%

Deduction 24%

Take home salary 76%

If the take home pay is Rs.76, his salary is 100.

For 1% it is  $\frac{1}{76}$

For Rs.984.50, it is  $\frac{1}{76} \times 984.50$ .

For 100% it is  $\frac{984.50}{76} \times 100 = 1295.39$

100% i.e. gross pay = Rs.1295.40.

Example 1

75 litres of oil is taken out from a oil barrel of 200 litres capacity. Find out the percentage taken in this.

Solution

% of oil taken = Oil taken out (litres) / Capacity of Barrel (litres) x 100

$= \frac{75}{200} \times 100 = 37\frac{1}{2}\%$

Example 2

A spare part is sold with 15%. Profit to a customer, to a price of Rs.15000/-. Find out the following (a) What is the purchase price (b) What is the profit.

Solution: CP = x ,

CP = cost price

SP = sale price

SP=CP+15%of CP

$15000 = x + \frac{15x}{100} = \frac{100x + 15x}{100}$

$x = \frac{1500000}{115} = 13043.47$

Profit = SP-CP = 15000-13043.47 = 1956.53

Purchase price = Rs.13,043/, Profit = Rs. 1957

### Example 3

Out of 80000 cars, which were tested on road, only 16000 cars had no fault. What is the percentage in this acceptance.

$$= \frac{16000}{80000} \times 100 = \frac{100}{5} = 20\%$$

### Example 4

The price of a motor cycle dropped to 92% of original price and now sold at Rs. 18000/- What was the original price.

Solution

Present price of Motor cycle Rs. 18000

This is the value of 92% of original price

$$\text{Original Price} = 18000 \times \frac{100}{92} = \frac{1800000}{92}$$

$$= \text{Rs. } 19565$$

### Example 5

A Motor vehicle uses 100 litres of Petrol per day when travelling at 30 kmph. After top overhauling the consumption falls to 90 litres per day. Calculate percentage of saving.

Solution

Percentage of saving = Decrease in consumption / Original consumption x 100

$$= (100 - 90) \frac{\text{litres}}{100} \times 100$$

$$= \frac{10}{100} \times 100$$

= 10% Saving in fuel.

## Assignment

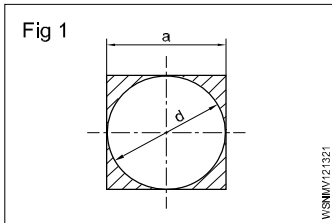
- 

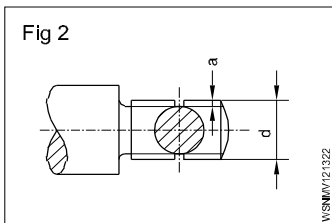
a = 400mm (side of square)  
d = 400 mm  
Wastage = \_\_\_\_\_ %.
- 

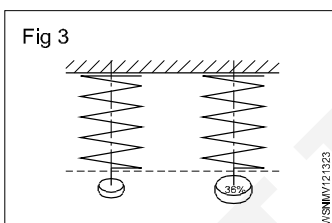
d = 26mm  
'a' depth of u/cut = 2.4mm  
reduction of area at cross-section = \_\_\_\_\_ %
- 

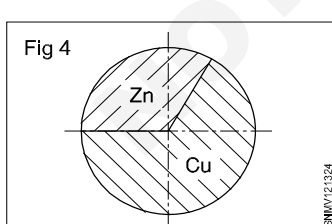
Percentage of increase = 36%  
Value of increase = 611.2 N/mm<sup>2</sup>  
Original tensile strength = \_\_\_\_\_ N/mm<sup>2</sup>.
- 

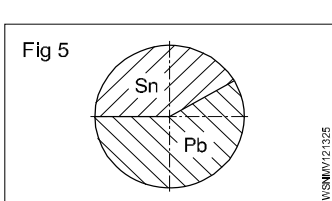
Copper in alloy = 27 kg  
Zinc in alloy = 18 kg  
% of Copper = \_\_\_\_\_ %  
% of Zinc = \_\_\_\_\_ %.
- 

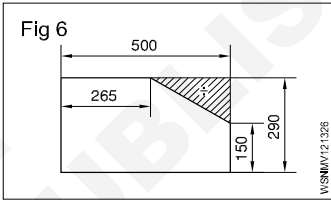
Weight of alloy = 140 Kgf  
Weight of Sn 40%  
Pb = \_\_\_\_\_ Kgf  
Sn = \_\_\_\_\_ Kgf.
- 

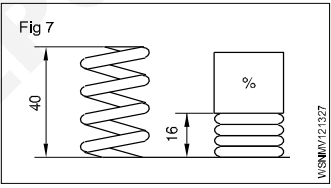
Shaded portion = \_\_\_\_\_ %.
- 

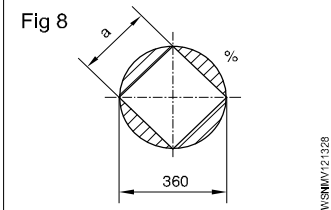
Compression length = \_\_\_\_\_ %.
- 

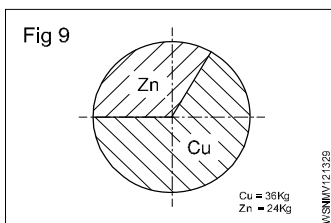
d = 360 mm  
a = 0.707 x d  
Wastage = \_\_\_\_\_ %.
- 

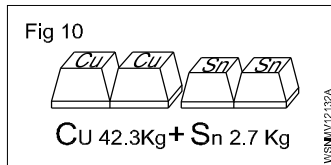
Cu = 36 Kg  
Zn = 24 Kg  
Cu = \_\_\_\_\_ %  
Zn = \_\_\_\_\_ %
- 

Cu = 42.3 Kg  
Sn = 2.7 Kg  
Cu \_\_\_\_\_ %  
Sn = \_\_\_\_\_ %.

## Square root, Ratio and Proportions, Percentage - Changing percentage to decimal and fraction

### Conversion of Fraction into Percentage

1 Convert  $\frac{1}{2}$  into percentage.

$$\begin{aligned}\text{Solution: } \frac{1}{2} \times 100 \\ &= 50\%\end{aligned}$$

2 Convert  $\frac{1}{11}$  into percentage

$$\begin{aligned}\text{Solution: } \frac{1}{11} \times 100 &= \frac{100}{11} \\ &= 9.01\%\end{aligned}$$

Convert the following fraction into percentage.

1  $\frac{1}{4}$

2  $\frac{1}{5}$

3  $\frac{2}{3}$

4  $\frac{3}{8}$

### Conversion of Percentage into Fraction

1 Convert 24% into fraction.

$$\text{Solution: } \frac{24}{100} = \frac{6}{25}$$

2 Convert  $33\frac{1}{3}\%$  into fraction.

$$\begin{aligned}\text{Solution: } \frac{33\frac{1}{3}}{100} &= \frac{\frac{100}{3}}{100} = \frac{100}{3} \times \frac{1}{100} \\ &= \frac{1}{3}\end{aligned}$$

Convert the following percentage into fraction

1 15%

2  $87\frac{1}{2}\%$

3 80%

4 12.5%

### Conversion of Decimal Fraction into Percentage

1 Convert 0.35 into percentage.

$$\begin{aligned}\text{Solution: } 0.35 \times 100 \\ &= 35\%\end{aligned}$$

2 Convert 0.375 into percentage.

$$\begin{aligned}\text{Solution: } 0.375 \times 100 \\ &= 37.5\%\end{aligned}$$

Convert the following Decimal Fraction into Percentage

1 0.2

2 0.004

3 0.875

4 0.052

### Conversion of Percentage into Decimal fraction

1 Convert 30% into decimal fraction.

$$\text{Solution: } \frac{30}{100} = 0.3$$

2 Convert  $33\frac{1}{3}\%$  into decimal fraction.

$$\begin{aligned}\text{Solution: } \frac{33\frac{1}{3}}{100} &= \frac{\frac{100}{3}}{100} = \frac{100}{3} \times \frac{1}{100} \\ &= \frac{1}{3} = 0.333\end{aligned}$$

Convert the following percentage into decimal fraction

1 15%

2 7%

3  $12\frac{1}{2}\%$

4 90%



**Material science - Types of plastics and its properties (warpage & shrinkage)****Introduction to Plastic**

Plastic is defined as a material that contains an essential ingredient an organic substance of large molecular weight. It is also defined as polymers of long carbon chains.

Carbon atoms are linked in chains and are produced in long-chain molecules.

The word, plastic, was derived from the word 'Plastikos' meaning 'to mould' in Greek. Fossil fuels have compounds containing hydrogen and carbon (hydrocarbon) which act as building blocks for long polymer molecules. These building blocks are known as monomers, they link together to form long carbon chains called polymers.

**Types of Plastic**

There are a lot of different types of plastic available today, each with its own unique set of properties and uses. The most prominent categories are defined and discussed below:

- 1 Polyethylene Terephthalate (PET)
- 2 Acrylonitrile Butadiene Styrene (ABS)
- 3 Polyvinyl Chloride (PVC)
- 4 Polypropylene (PP)
- 5 Polyethylene (PE)
- 6 Polystyrene (PS)
- 7 Acrylic or Polymethyl Methacrylate (PMMA)
- 8 Polycarbonate (PC)

**1 Polyethylene Terephthalate (PET)**

PET is one of the most produced synthetic plastic and is the most popular thermoplastic resin in the polyester family. This material is found in many everyday items, including food and drink containers, and garment fibers.

**2 Acrylonitrile Butadiene Styrene (ABS)**

ABS is a glossy, highly processable, flexible, strong, and impact-resistant material that is made by polymerizing styrene and acrylonitrile in the presence of polybutadiene. ABS plastic sheeting is relatively cheap to manufacture and is frequently used in the automotive and refrigeration sectors, as well as in items like boxes, protective headgear, luggage, gauges, and children's toys.

**3 Polyvinyl Chloride (PVC)**

PVC, the third most common synthetic plastic polymer, can be made flexible or rigid. It is well known for its versatility in mixing with other materials. Rigid PVC is extensively used in construction materials, windows, bottles, doors, non-food packaging, and other products.

**4 Polypropylene (PP)**

Polypropylene is a thermoplastic polymer and also the second most produced synthetic plastic. PP is one of the most flexible thermoplastics, it is stronger than PE. Polypropylene sheets are used to produce food containers, automobile components, medical devices, and laboratory equipment

**5 Polyethylene (PE)**

The most common plastic on the planet, polyethylene, comes in multiple densities. This results in plastics with distinct physical properties. Uses of UHMWPE are bearings, artificial ice skating rinks, hydraulic seals, and biomaterial for spine, knee, and hip implants due to its high density and low friction properties.

**6 Polystyrene (PS)**

Polystyrene, better known as Styrofoam, comes in both solid and foamed forms. This plastic is used in egg cartons, disposable dinnerware, insulation, and drinking cups because of its low cost per unit weight and ease of production. While common, it is extremely combustible and releases toxic compounds when heated.

**7 Acrylic or Polymethyl Methacrylate (PMMA)**

As a transparent thermoplastic material that is lightweight and break-resistant, acrylic is great for optical products and gadgets. Mirrors and plexiglass are typically made using sheets of acrylic.

**8 Polycarbonate (PC)**

Polycarbonate is a good engineering plastic that is strong, stable, and transparent. Its strength-to-weight ratio is 250 times better than steel's and it has glass-like clarity. Transparent polycarbonate sheets are 30 times stronger than acrylic and are easy to work with, mold, and thermo- or cold-form.

**Properties of Plastic**

Plastics can have a wide range of physical and chemical properties, depending on their chemical structures and how they are processed. However, some general physical and chemical properties are common to most plastics. These properties are given below:

**Physical properties of plastic include:**

- 1 Density:** Plastics come in many different densities, from as low as 0.9 g/cm<sup>3</sup> for foamed plastics to as high as 1.5 g/cm<sup>3</sup> for some engineering plastics.
- 2 Melting Point:** The melting points of plastics vary widely depending on the type of polymer. Some plastics have low melting points and can be easily molded while others have high melting points and require specialized processing techniques.

- 3 **Hardness:** Plastics can range from soft and flexible to hard and rigid, depending on the specific polymer and its processing.
- 4 **Transparency:** Some plastics are optically transparent while others are opaque and block light. Many transparent plastics can accept dye if you need them to be opaque.
- 5 **Permeability:** Plastics can be permeable to gasses and liquids, which can be an advantage in some applications (such as food packaging) and a disadvantage in others (such as chemical storage).

#### Chemical properties of plastic include:

- 1 **Resistance to Chemicals:** Many types of plastic are resistant to industrial chemicals, acids, and other corrosive substances. This makes them useful in a variety of industrial applications.
- 2 **Stability:** Some plastics are sensitive to heat, light, and radiation, which can cause them to degrade over time. UV stabilizers and antioxidants are often added to plastics to improve their stability.
- 3 **Flammability:** Plastics can be highly flammable, and many of them release toxic gasses when burned. Flame retardants are often added to plastics to improve their fire resistance.
- 4 **Degradation:** The rate at which plastics degrade depends on a variety of factors, including the type of plastic, the conditions to which they are exposed, and the specific environmental factors they encounter. Some plastics, degrade very slowly. Other plastics, such as polylactic acid (PLA), are designed to be biodegradable and can break down much more quickly when exposed to moisture, heat, or microorganisms.

- 5 **Solubility:** Each plastic has unique solubility characteristics. Plastics that are amorphous (not crystalline), like polystyrene and polycarbonate, are more soluble in typical organic solvents than crystalline ones.
- 6 **Reactivity:** Plastics can be reactive in different ways, depending on their chemical composition. For example, polyethylene reacts with oxygen to form carbon dioxide and water while polypropylene is relatively unreactive and stable in most chemical environments.
- 7 **Biodegradability:** Some plastics, such as polyethylene, are not biodegradable and can persist in the environment for hundreds of years. Others, such as polycaprolactone (PCL), are biodegradable and can be broken down by bacteria and fungi over time.
- 8 **Recyclability:** Plastics can be difficult to recycle since they each have different chemical compositions and properties. Some types of plastics are easier to recycle than others, and recycling methods vary depending on the type of plastic.

#### Shrinkage and Warpage

- Injection molding and shrinkage
- Basic causes of shrinkage and warpage
- Designing accurate parts considering warpage

#### Introduction to Shrinkage and Warpage

Part shrinkage may be thought of as a geometric reduction in the size of the part. If the shrinkage is uniform, the part does not deform and change its shape, it simply becomes smaller.

Warpage results when shrinkage is not uniform. If regions of the part shrink unequally, stresses are created within the part which, depending on part stiffness, may cause the part to deform or change shape. In the long term parts can even crack.

**Mass, Weight, Volume and Density - Mass, volume, density, weight and specific gravity**

**Mass**

Mass of a body is the quantity of matter contained in a body. The unit of mass in F.P.S system is pound (lb), in C.G.S. system gram (gr) and in M.K.S and S.I systems kilogram (kg). 1ton which is 1000kg is also used sometimes. The conversion factor is 1000. Three decimal places are shifted during conversion. E.g. 1 ton = 1000 kg 1g = 1000mg.

m - mass of a body

g - acceleration due to gravity in metre/sec<sup>2</sup> = 9.81 m/sec<sup>2</sup>

V - volume of the body

ρ - density (pronounced as 'rho')

W or FG - weight or weight force

**Mass (Fig 1)**

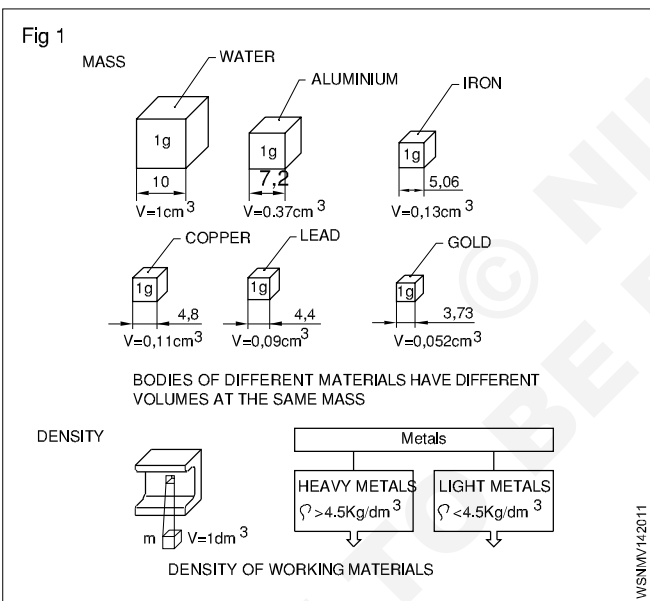

**Density**

Density is the mass of a body per unit volume. Hence its unit will be gr/cm<sup>3</sup> or kg/dm<sup>3</sup> or ton/m<sup>3</sup>.

$$\text{Density} = \frac{\text{mass}}{\text{volume}} = \frac{m}{v} = \rho$$

**Weight (Fig 2)**

Weight is the force with which a body is attracted by the earth towards its centre. It is the product of the mass of the body and the acceleration due to gravity. The weight of a body depends upon its location.

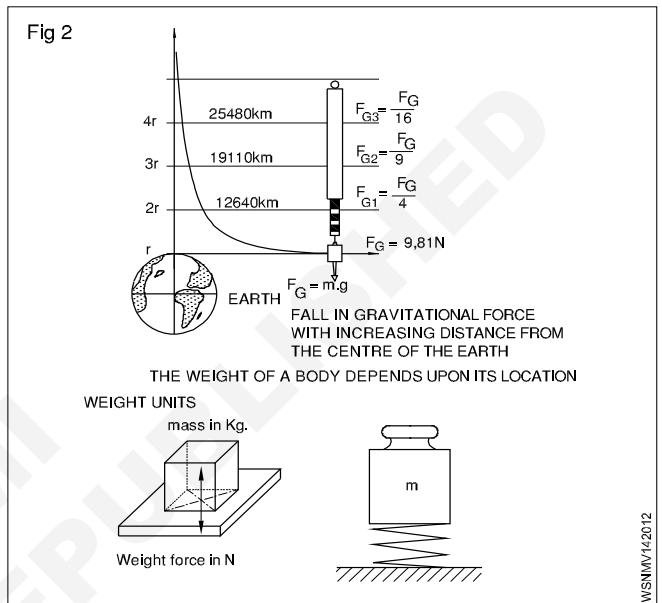

$$\text{weight} = W \text{ or } FG = \text{mass} \times \text{gravitational force} = m \times g$$

System	Absolute unit	Derived unit	Conversion
F.P.S. system	1 poundal	1 Lb wt	32.2 poundals (1 lb x 1 ft/sec <sup>2</sup> = 1 pound)
C.G.S. system	1 dyne 1 gr x 1 cm/sec <sup>2</sup>	1 Gr.wt	981 dynes
M.K.S.	Newton	1 kg.wt	1 Newton =
S.I.system	Newton	Newton	1 kg x 1 m/sec <sup>2</sup>

**1 kg.wt = 9.81 Newton (approximately 10N)**      **1 Newton = 10<sup>5</sup> dynes.**

## Difference between mass and weight

S. No	Mass	Weight
1	Mass is the quantity of matter in a body (ie) measurement of matter in a body	Weight is measure of amount of force acting on mass due to acceleration due to gravity
2	It does not depend on the position or space	It depends on the position, location and space
3	Mass of an object will not be zero	Weight of an object will be zero if gravity is absent
4	It is measured using by physical balance	It is measured using by spring balance
5	It is a scalar quantity	It is a vector quantity
6	When immersed in water mass does not change	When immersed in water weight will change
7	The unit is in grams and kilogram	The unit is in kilogram weight, a unit of force

**Mass and weight are different quantities.**

**Mass of a body is equal to volume x density.**

**Weight force is equal to mass x acceleration due to gravity.**

### Weight , Density and Specific gravity

It is now seen that the mass of a substance is measured by its weight only without any reference to volume. But if equal weights of lead & aluminium, are compared the volume of lead is much smaller than volume of aluminium. So we can now say that lead is more dense than aluminium,. i.e In other words the density of lead is greater than aluminium. (Fig 3 & 4)

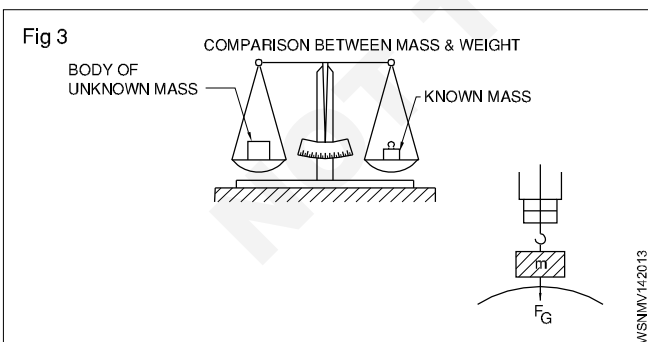

The relation of mass and volume is called density.

The density expresses the mass of volume E.g. 1 dm<sup>3</sup> of water has the mass of 1kg - thus the density of 1kg/dm<sup>3</sup> (Fig 2)

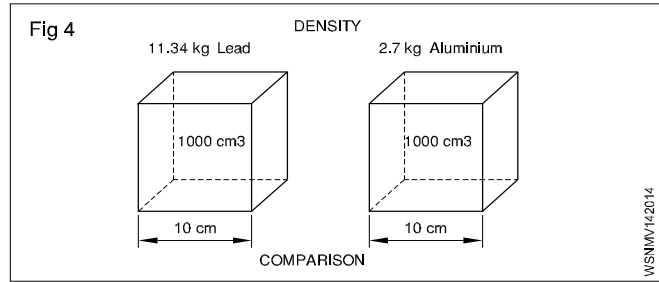

### Unit

The density is measured as below

MKS/SI= Kg/m<sup>3</sup>, CGS = 1 gm/cm<sup>3</sup> FPS = lbs/c ft

Solids	gm/cc	Liquids	gm/cc
1 Aluminum	2.7	Water	1.00
2 Lead	11.34	Petrol	0.71
3 Cast iron	6.8 to 7.8	Oxygen	1.43
4 Steel	7.75 to 8.05	Diesel Oil	0.83

The specific gravity of a substance is also called its relative density.

Formula

Specific gravity (or) Relative density =  $\frac{\text{Density of the substance}}{\text{Density of the water at } 4^{\circ}\text{C}}$

=  $\frac{\text{Mass of any volume of a substance}}{\text{Mass of an equal volume of water at } 4^{\circ}\text{C}}$

### Comparison Between Density And Specific Gravity (Relative Density)

Density	Relative density or Specific gravity
Mass per unit volume of a substance is called its density Its unit is gm per cu cm; lbs per cu.ft and kg/cubic meter	The density of substance to density of water at 4°C is its relative density It has no unit of measurement simply expressed in a number
Density = $\frac{\text{Mass}}{\text{Volume}}$	Relative density = $\frac{\text{Density of the substance}}{\text{Density of water at } 4^{\circ}\text{C}}$

Solids	Sp.gy	Liquids	Sp.gy
1 Aluminium	2.72	Petrol	0.71
2 Lead	11.34	Battery acid	1.2 to 1.23
3 Cast iron	6.8 to 7.8	Water	1.00
4 Steel	7.82	Diesel Oil	0.83

From the above table, we can calculate the weight of any given volume of a substance (say Diesel oil) in any units provided we know the specific gravity of the substance. Also vice-versa for volume of density is known.

## Heat & Temperature and Pressure - Concept of heat and temperature, effects of heat, difference between heat and temperature, boiling point & melting point of different metals and non-metals

### Heat

It is a form of energy. Heat energy can be transformed into other forms of energies. Heat flows from a hotter body to a colder body. (Fig 1)

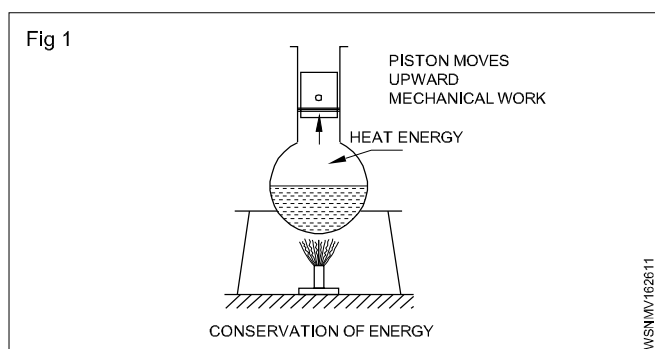

### Units of heat

**Calorie:** It is the quantity of heat required to raise the temperature of 1 gram of water through 1°C.

**BTHU:** It is the quantity of heat required to raise 1 lb of water through 1°F. (British thermal unit).

**C.H.U;** It is the quantity of heat required to raise 1 lb of water through 1°C.

**Joule :** S.I. Unit (1 Calorie = 4.186 joule)

### Effects of heat

- Change in temperature
- Change in size
- Change in state
- Change in structure
- Change in Physical properties

### Specific heat

The quantity of heat required to raise the temperature of one gm of a substance through 1°C is called specific heat. It is denoted by the letter 's'.

Specific heat of water	= 1
Aluminium	= 0.22
Copper	= 0.1
Iron	= 0.12

### Thermal capacity:

It is the amount of heat required to raise the temperature of a substance through 1°C is called the thermal capacity of the substance.

$$\text{Thermal capacity} = ms \text{ calories.}$$

**Calorific value:** The amount of heat released by the complete combustion of unit quantity of the fuel (Mass or volume) is known as calorific value of fuels.

### Water equivalent

It is the mass of water which will absorb the same amount of heat as the given substance for the same temperature rise. Water equivalent = Mass of the substance x specific heat of the substance.

Therefore water equivalent =  $ms$

### Types of heat

- 1 Sensible heat
- 2 Latent heat

#### 1 Sensible heat

Sensible heat is the heat absorbed or given off by a substance without changing its physical state. It is sensible and can be absorbed by the variation of temperature in the thermometers.

#### 2 Latent heat

The heat gained or given by the substance during a change of state (from solid to liquid to gas) is called latent heat or hidden heat. The heat absorbed or given off does not cause any temperature change in the substance.

Types, 1. Latent heat of fusion of solid

2. Latent heat of vaporisation of solid.

#### 1 Latent heat of fusion of solid

The amount of heat required per unit mass of a substance at melting point to convert it from the solid to the liquid state is called latent heat of fusion of solid. Its unit is cal/gram.

#### Latent heat of fusion of ice

The amount of heat required to convert per unit mass of the ice into water at 0°C temperature is called latent heat of fusion of ice.

Latent heat of fusion of ice(L) = 80 cal/gram

#### 2 Latent heat of vaporisation of liquid

The amount of heat required to vaporise a unit mass of liquid at its boiling point is called latent heat of vaporisation.

#### Latent heat of vaporisation of water or latent heat of steam

The amount of heat required to convert into steam of a unit mass of water at its boiling point (100°C) is called latent heat of vaporisation of water or latent heat of steam.

Latent heat of steam(L) = 540 cal/gram

## Temperature

It is the degree of hotness or coldness of a body. The temperature is measured by thermometers.

### Difference between heat and temperature

Heat	Temperature
1 It is a form of energy.	This tells the state of heat.
2 Its unit is calorie.	Its unit is degree.
3 Heat is measured by calorimeter.	Temperature is measured by thermometer.
4 By adding quantity of heat of two substances their total heat can be calculated.	By adding two temperatures we cannot find the temperature of the mixture.
5 By heating a substance the quantity of heat is increased regardless of increase in temperature.	Two substances may read the same temperature though they might be having different amount of heat in them.

## Boiling point

Any substance starts turning into a gas shows the temperature at which it boils this is known as the boiling point. The boiling point of water is 100°C.

## Melting point

The temperature at which any solid melts into liquid or liquid freezing to solid is called the melting point of substance. The melting point of ice is 0°C.

### List of melting point and boiling point of metals and Non -metals

Metals and Non-metals	Melting point °C	Boiling point °C	Metals and Non-metals	Melting point °C	Boiling point °C
Aluminium	660.25	2519	Manganese	1246	2061
Argon	-189.19	-185.85	Mercury	-38.72	357
Arsenic	817	614	Molybdenum	2617	4639
Barium	729	1897	Nickel	1453	2913
Beryllium	1287	2469	Nitrogen	-209.86	-195.79
Bromine	-7.1	58.8	Oxygen	-226.65	-182.95
Cadmium	321.18	767	Phosphorus (white)	44.1	280
Calcium	839	1484	Plutonium	640	3228
Carbon (diamond)	3550	4827	Potassium	63.35	759
Carbon (graphite)	3675	4027	Radium	700	1737
Chlorine	-100.84	-34.04	Silicon	1410	3265
Cobalt	1495	2927	Silver	961	2162
Copper	1084.6	2562	Sodium	98	883
Gold	1064.58	2856	Sulfur	115.36	444.6
Helium	-	-268.93	Tin	232.06	2602
Hydrogen	-259.98	-252.87	Titanium	1660	3287
Iodine	113.5	184.3	Tungsten (wolfram)	3422	5555
Iridium	2443	4428	Uranium	1132	4131
Iron	1535	2861	Zinc	419.73	907
Lead	327.6	1749			
Lithium	180.7	1342			
Magnesium	650	1090			

Mensuration - Area and perimeter of square, rectangle and parallelogram

In Engineering field, an Engineer has to estimate the material, manpower, machinery, etc. required to prepare the geometrical objects. Hence we must be very conversant with all relevant formulae connected with geometrical objects.

- Length - l unit
- Breadth or width - b unit
- Diagonal - d unit
- Diameter - d unit

- Radius - r unit
- Semi perimeter - S unit
- Perimeter - P unit
- Circumference - C unit
- Area - A unit<sup>2</sup>
- Total surface area - T.S.A unit<sup>2</sup>
- Lateral surface area - L.S.A unit<sup>2</sup>
- Volume - V unit<sup>3</sup>

**Square**

This is also a four sided figure, opposite sides are parallel. All the four sides are equal. Angle between adjacent side are 90°.

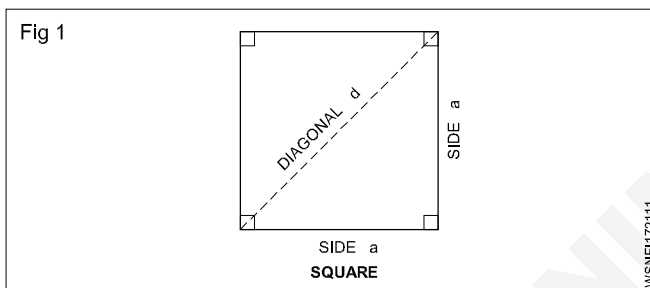

$A = a^2$  (or) unit<sup>2</sup>  
 $P = 4a$  unit  
 $d = \sqrt{2} a$  unit  
 $a = \frac{d}{\sqrt{2}}$  unit where  $\sqrt{2} = 1.414$

Find the area of a brass sheet in the form of a square whose perimeter is 31.2 cm.

Perimeter(P) = 4a = 31.2 cm  
 $\therefore a = \frac{31.2}{4} = 7.8$  cm  
 Area (A) = a<sup>2</sup>  
 $= 7.8 \times 7.8 = 60.84$  cm<sup>2</sup>

**Examples**

- 1 Find out the circumference, diagonal and area of a square, whose side is 18 cm.
  - Side of the square (a) = 18 cm
  - Perimeter (P) = 4a  
 $= 4 \times 18 = 72$  cm
  - Diagonal (d) =  $\sqrt{2} \times a$   
 $= \sqrt{2} \times 18 = 1.414 \times 18$   
 $= 25.45$  cm

Area (A) = a<sup>2</sup>  
 $= 18 \times 18 = 324$  cm<sup>2</sup>

**Perimeter of square = 72 cm**

**Diagonal = 25.45 cm ; Area = 324 cm<sup>2</sup>**

- 2 If the diagonal of a square measure 10 cm. Find area of the square.

Diagonal of the square (d) =  $\sqrt{2} a = 10$  cm  
 Side (a) =  $\frac{d}{\sqrt{2}}$   
 Area (a<sup>2</sup>) =  $\frac{d}{\sqrt{2}} \times \frac{d}{\sqrt{2}} = \frac{d^2}{2}$   
 $= \frac{10^2}{2} = \frac{100}{2}$   
 $= 50$  cm<sup>2</sup>  
**Area of the square = 50 cm<sup>2</sup>**

- 3 The perimeter of one square is 748 cm and that of Another is 336 cm. Find the total area of the two squares.

Side of the square (a) =  $\frac{\text{Perimeter}}{4}$

**1<sup>st</sup> square**

Side (a) =  $\frac{\text{Perimeter of 1<sup>st</sup> square}}{4}$   
 $= \frac{748}{4} = 187$  cm  
 Area (A) = a<sup>2</sup>  
 $= 187 \times 187$   
 $= 34,969$  cm<sup>2</sup>

**2<sup>nd</sup> square**

Side (a) =  $\frac{\text{Perimeter of 2<sup>nd</sup> square}}{4}$   
 $= \frac{336}{4} = 84$  cm

$$\begin{aligned} \text{Area (A)} &= a^2 \\ &= 84 \times 84 \\ &= 7,056 \text{ cm}^2 \end{aligned}$$

$$\begin{aligned} \text{Total area of two squares} &= 34,969 + 7,056 \\ &= 42,025 \text{ cm}^2 \end{aligned}$$

## Assignment

- Find the Area, Perimeter and diagonal of a square steel plate whose side measures 28.1 cm.
- Find the area of a square whose diagonal is equal to 8.5 cm.
- Find the area of the square if the side of the square is 28 cm.
- Find its side if the area of the square field is 169 m<sup>2</sup>.
- Find the area of the square if the diagonal of the square is 20 cm.
- Find the perimeter of a square whose diagonal is 144 m.
- Find the area if the perimeter of a square plot is 48 m.

## Rectangle

This is a four sided figure. Opposite sides are parallel. Angles between adjacent sides are 90°.

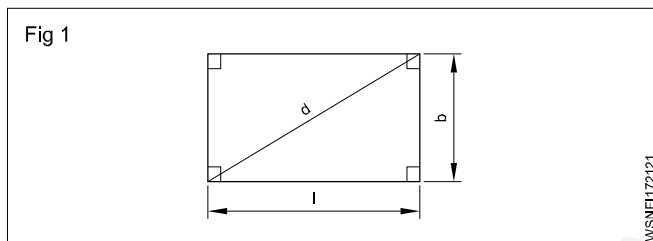

$$A = \text{Area} = \text{length} \times \text{breadth} = l \cdot b \cdot \text{unit}^2$$

$$P = \text{Perimeter} = 2(l + b) \text{ unit}$$

$$\text{Diagonal} = \sqrt{l^2 + b^2} \text{ unit}$$

### Examples

- Find the Area, Perimeter and diagonal of a rectangle whose length and breadth are 144 mm and 60 mm respectively.

$$\begin{aligned} \text{Area} = A &= l \times b \text{ unit}^2 \\ &= 144 \times 60 = 8640 \text{ mm}^2 \end{aligned}$$

$$\begin{aligned} \text{Perimeter} = P &= 2(l + b) \text{ unit} \\ &= 2(144 + 60) \\ &= 2 \times 204 = 408 \text{ mm} \end{aligned}$$

$$\begin{aligned} \text{Diagonal} = d &= \sqrt{l^2 + b^2} \text{ unit} \\ &= \sqrt{144^2 + 60^2} \\ &= \sqrt{20736 + 3600} \\ &= \sqrt{24336} = 156 \text{ mm} \end{aligned}$$

- The perimeter of a rectangle is equal to 42 cm. If its breadth is 9 cm. Find the length of the rectangle.

$$\text{Perimeter} = 42 \text{ cm}$$

$$\text{Breath} = 9 \text{ cm}$$

$$\text{Length} = ?$$

$$\text{Perimeter} = P = 2(l + b)$$

$$2(l + 9) = 42$$

$$l + 9 = 42 \div 2$$

$$l + 9 = 21$$

$$l = 21 - 9$$

$$l = 12 \text{ cm}$$

- The perimeter of a rectangle is 48 cm and its length is 4 cm more than its width. Find the length and breadth of the rectangle.

$$\text{Perimeter (P)} = 48 \text{ cm}$$

$$\text{Breath (b)} = x$$

$$\text{Length (l)} = x + 4$$

$$2(l + b) = \text{Perimeter}$$

$$2(x + 4 + x) = 48$$

$$2(2x + 4) = 48$$

$$4x + 8 = 48$$

$$4x = 48 - 8$$

$$x = \frac{40}{4} = 10$$

$$x = \text{breadth} = 10 \text{ cm}$$

$$\text{length} = x + 4 = 10 + 4 = 14 \text{ cm}$$



- 4 How many rectangular pieces of 50 cm x 20 cm can be cut out from a sheet of 1000 cm x 500 cm.

Sheet size = 1000 cm x 500 cm

Size of the rectangular piece to be cut = 50 cm x 20 cm

$$\text{No. of pieces to be cut in lengthwise} = \frac{1000}{50} = 20$$

$$\text{No. of pieces to be cut in breadthwise} = \frac{500}{20} = 25$$

$$\begin{aligned} \text{Total no. of pieces to be cut out} &= 20 \times 25 \\ &= \mathbf{500} \end{aligned}$$

- 5 The perimeter of a rectangle is 320 metre. Its sides are in the ratio of 5:3. Find the area of the rectangle.

$$\text{Ratio} = 5:3 = l : b$$

$$\text{length } l = 5x$$

$$\text{breadth } b = 3x$$

$$2(l + b) = \text{Perimeter}$$

$$2(5x + 3x) = 320$$

$$2(8x) = 320$$

$$16x = 320$$

$$x = \frac{320}{16} = 20$$

$$l = 5x = 5 \times 20 = 100 \text{ m}$$

$$b = 3x = 3 \times 20 = 60 \text{ m}$$

$$\begin{aligned} \text{Area} &= l \times b \quad (\text{length} = 100\text{m, breath} = 60\text{m}) \\ &= 100 \times 60 \end{aligned}$$

$$\text{Area} = 6000 \text{ m}^2$$

## Assignment

- Find the area of a rectangular plot whose sides are 24 metres and 20 metres respectively. Also find the perimeter of the plot.
- How many rectangular pieces of 5 cm x 4 cm will you get out of 65 cm x 30 cm brass sheet?
- Find its breadth and area if the perimeter of a rectangle is 400 metre and its length is 140 m.
- Find its area, if the opposite sides of a rectangle are 64 cm and 25 cm respectively.
- What is the width of the rectangle if a rectangle has an area of 224 cm<sup>2</sup> and length 16 cm.
- What is the length of the diagonal of a rectangle with sides 16 cm and 12 cm?
- Find the area of the rectangle if the perimeter of the rectangle is 100 cm and the ratio of its length and breadth is 3:2.

## Parallelogram

This is also a four sided figure, opposite side being parallel to each other.

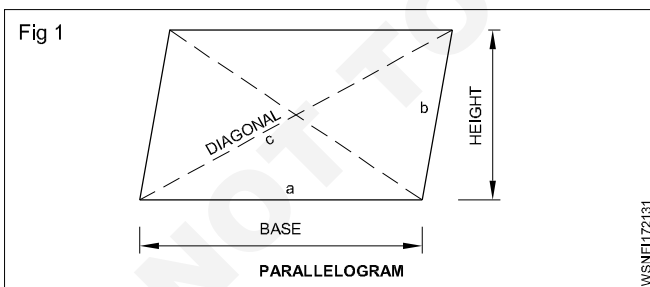

Area of parallelogram = base x height

$$\text{or} = 2x\sqrt{s(s-a)(s-b)(s-c)}$$

Where

$$s = \frac{a+b+c}{2}$$

a and b are adjacent sides.

$$P = 2(a+b)$$

### Examples

- 1 The base and height of a parallelogram are 7.1 cm and 2.85 cm. Calculate its area.

$$\begin{aligned} A &= \text{base} \times \text{height units}^2 \\ &= 7.1 \times 2.85 \\ &= \mathbf{20.235 \text{ cm}^2} \end{aligned}$$

- 2 Find the height of a parallelogram whose area is 20 cm<sup>2</sup> and base is 10 cm.

$$\begin{aligned} A &= \text{base} \times \text{height units}^2 \\ h &= \frac{\text{area}}{\text{base}} \\ &= \frac{20}{10} \\ &= \mathbf{2 \text{ cm}} \end{aligned}$$

3. Two sides of a parallelogram are 12 cm and 8 cm. The diagonal is 10 cm long. Find the area of the parallelogram.

$$\begin{aligned} \text{Area } A &= 2x\sqrt{s(s-a)(s-b)(s-c)} \text{ units}^2 \\ s &= \frac{a+b+c}{2} \\ &= \frac{12+8+10}{2} \\ &= \frac{30}{2} \\ &= 15 \end{aligned}$$

$$\begin{aligned} A &= 2x\sqrt{15(15-12)(15-8)(15-10)} \\ &= 2x\sqrt{15 \times 3 \times 7 \times 5} \\ &= 2x\sqrt{1575} \\ &= 2 \times 39.686 \\ \text{Area } A &= 79.37 \text{ cm}^2 \end{aligned}$$

## Assignment

- 1 Find the area of a parallelogram, if its base and height are 8.1 cm and 30.8 cm respectively.
- 2 Find the area of a parallelogram, if the sides of a field in the shape of parallelogram are 12 m and 17 m and one of the diagonal is 25 m.
- 3 Find the base of a parallelogram whose height is 12 cm and area is 120 cm<sup>2</sup>.
- 4 Find the height of a parallelogram whose base is 40 cm and area is 320 cm<sup>2</sup>.
- 5 Find the area of the land if the sides of a land in the shape of a parallelogram are 24 m and 28 m respectively and one of the diagonal is 30 m.
- 6 What is the perimeter of parallelogram if base is 10 cm and other side is 5 cm?
- 7 Find the area of parallelogram if its base and height are 25 cm and 12 cm.
- 8 Find the base of a parallelogram if height is 15 cm and area is 150 cm<sup>2</sup>.
- 9 Find the height of a parallelogram if base is 80 cm and area is 640 cm<sup>2</sup>.
- 10 Find the area of parallelogram if its base and height are 15 cm and 8 cm.
- 11 Calculate the perimeter and area of parallelogram if base, height are 12.7 cm, 5.5 cm and other side is 6.5 cm
- 12 Find the height of parallelogram if the area is 20 cm<sup>2</sup> and base is 10 cm

Mensuration - Area and perimeter of triangles

Triangles

Tri means three. Hence tri- angle means three angled figure. For construction of three angled figure, there should be three sides. Hence triangle means three sided figure. Sum of the three angles of any triangle = 180°.

i Any triangle.

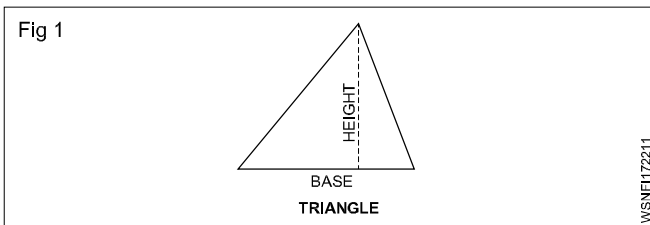

Area of any triangle =  $\frac{1}{2}$  x Base x Height unit<sup>2</sup>

ii Isosceles Triangle

In this triangle two of its sides are equal.

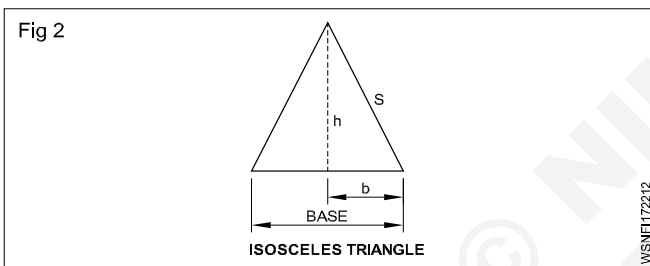

Area of isosceles triangle =  $\frac{1}{2}$  x Base x Height

Where

base = 2.b

s = One of equal sides (or) Slant height

h = Height =  $\sqrt{s^2 - b^2}$

Area of isosceles triangle =  $\frac{1}{2}$  x 2b x  $\sqrt{s^2 - b^2}$

= b .  $\sqrt{s^2 - b^2}$  unit<sup>2</sup>

(Where b= half of base)

(or) Area of Isosceles triangle =  $\frac{1}{4}$ b  $\sqrt{4a^2 - b^2}$  unit<sup>2</sup>

a = Equal sides

b = Base

iii Equilateral triangle

In this triangle all the three sides are equal. Hence angle between adjacent sides is 60° (Three angles total = 180°)

angle between sides =  $\frac{180}{3} = 60^\circ$

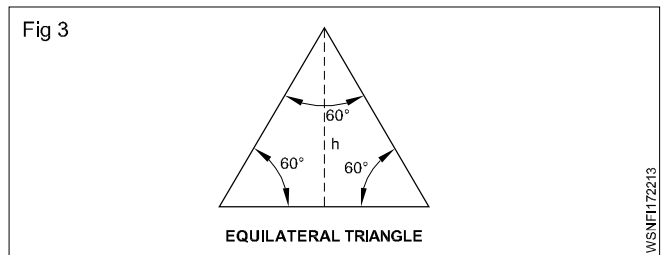

Area of equilateral triangle =  $\frac{\sqrt{3}}{4}$  x side<sup>2</sup>

=  $\frac{\sqrt{3}}{4}$  x a<sup>2</sup> unit<sup>2</sup>

Where  $\sqrt{3} = 1.732$

Perimeter P = 3a unit

P =  $\frac{\sqrt{3}}{2}$ a unit

iv Scalene triangle

In this triangle the sides are not equal. Angles between the sides, are also not equal. we may also call this triangle as irregular triangle.

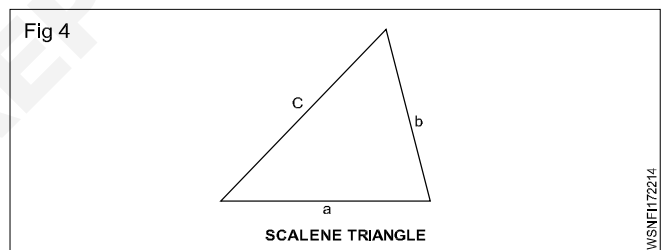

Area of triangle =  $\sqrt{s(s-a)(s-b)(s-c)}$  unit<sup>2</sup>

where

a,b,c are sides of triangle

s = Semi perimeter =  $\frac{a+b+c}{2}$  unit

v Right angled triangle

In this triangle, angle between one of two adjacent sides is 90°. Right angle means 90°. That's why right angled triangle means, one of the angles of this triangle is definitely 90°.

Area of right angled triangle

=  $\frac{1}{2}$  x Base x Height

=  $\frac{1}{2}$  bh unit<sup>2</sup>

Hypotenuse =  $\sqrt{\text{Base}^2 + \text{Height}^2}$

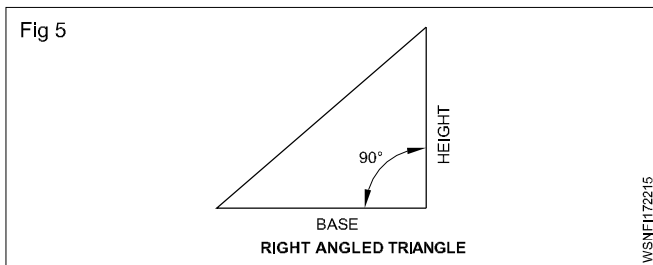

Where hypotenuse means, the diagonal or largest length of the side of right angled triangle.

### Examples

- 1 Calculate its area if the base and height of a Right angled triangle are 10 cm and 3.5 cm respectively.

Base (b) = 10 cm

Height (h) = 3.5 cm

Area (A) = ?

$$A = \frac{1}{2} \times b \times h$$

$$= \frac{1}{2} \times 10 \times 3.5$$

$$= 17.5 \text{ cm}^2$$

- 2 Calculate the base of a triangle having an area of 15 cm<sup>2</sup> and height is 3.5 cm.

Area (A) = 15 cm<sup>2</sup>

Height (h) = 3.5 cm

Base (b) = ?

$$\frac{1}{2} \times b \times h = A$$

$$\frac{1}{2} \times b \times 3.5 = 15$$

$$b = \frac{15 \times 2}{3.5}$$

$$= 8.57 \text{ cm}$$

- 3 Calculate the height of a triangle whose area is 60 cm<sup>2</sup> and base is 10 cm.

Area (A) = 60 cm<sup>2</sup>

Base (b) = 10 cm

Height (h) = ?

$$\frac{1}{2} \times b \times h = A$$

$$\frac{1}{2} \times 10 \times h = 60$$

$$h = \frac{60 \times 2}{10}$$

height h = 12 cm

- 4 Find the area of an isosceles triangle whose base is 6 cm long and each of the other two sides 5 cm long.

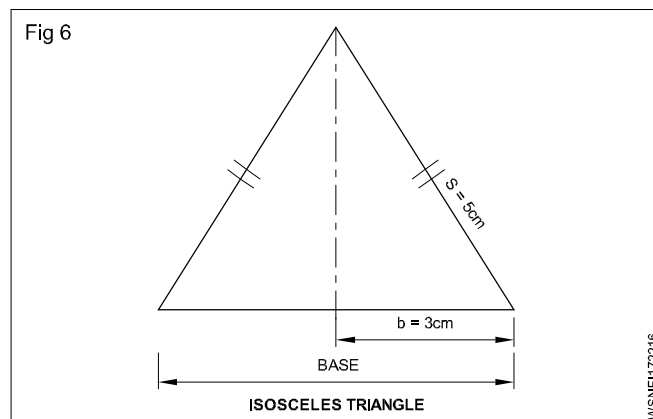

Base (b) = 6 cm =  $\frac{6}{2} = 3 \text{ cm}$

Equal sides or slant height 's' = 5 cm

Area (A) = ?

$$A = b \times \sqrt{s^2 - b^2}$$

$$= 3 \times \sqrt{5^2 - 3^2}$$

$$= 3 \times \sqrt{25 - 9}$$

$$= 3 \times \sqrt{16}$$

$$= 3 \times 4$$

$$= 12 \text{ cm}^2$$

or

$$A = \frac{1}{4} b \sqrt{4a^2 - b^2}$$

$$= \frac{1}{4} \times 6 \sqrt{4 \times 5^2 - 6^2}$$

$$= \frac{1}{4} \times 6 \times 8$$

$$= 12 \text{ cm}^2$$

- 5 Find its height if an isosceles triangle has base of 200 mm and its area is 2000 mm<sup>2</sup>.

Base = 200 mm

Area = 2000 mm<sup>2</sup>

h = ?

$$\frac{1}{2} \times b \times h = A$$

$$\frac{1}{2} \times 200 \times h = 2000$$

$$h = \frac{2000 \times 2}{200} = 20 \text{ mm}$$

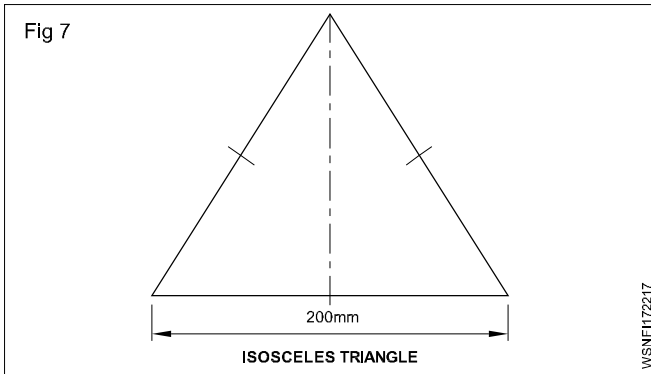

- 6 Find the area of an equilateral triangle whose side is 5 cm.

$$\begin{aligned} \text{Area} &= \frac{\sqrt{3}}{4} a^2 \text{ unit}^2 \\ &= \frac{1.732}{4} \times 5 \times 5 \\ &= \mathbf{10.825 \text{ cm}^2} \end{aligned}$$

- 7 Calculate its perimeter if one side of an equilateral triangle is 55 mm long.

$$\begin{aligned} \text{Side} &= 55 \text{ mm} \\ \text{Perimeter (P)} &= ? \\ P &= 3a \text{ unit} \\ &= 3 \times 55 \\ &= \mathbf{165 \text{ mm}} \end{aligned}$$

- 8 Find the area of the triangle having its sides are 9cm, 10cm and 12 cm.

$$\begin{aligned} \text{Semi Perimeter} &= \frac{a+b+c}{2} \text{ unit} \\ &= \frac{9+10+12}{2} = \frac{31}{2} \\ &= 15.5 \text{ cm} \\ \text{Area A} &= \sqrt{s(s-a)(s-b)(s-c)} \text{ unit}^2 \\ &= \sqrt{15.5(15.5-9)(15.5-10)(15.5-12)} \\ &= \sqrt{15.5 \times 6.5 \times 5.5 \times 3.5} \\ &= \sqrt{1939.4375} \\ &= \mathbf{44.03 \text{ cm}^2} \end{aligned}$$

- 9 Find the cost of polishing on both sides of a triangular metal plate has sides 60 cm, 50 cm and 20 cm at the rate of Rs.1.35 per 100 cm<sup>2</sup>

$$\text{Semi Perimeter} = \frac{a+b+c}{2} \text{ unit}$$

$$\begin{aligned} &= \frac{60+50+20}{2} = \frac{130}{2} \\ &= 65 \text{ cm} \end{aligned}$$

$$\begin{aligned} \text{Area A} &= \sqrt{s(s-a)(s-b)(s-c)} \text{ unit}^2 \\ &= \sqrt{65(65-60)(65-50)(65-20)} \\ &= \sqrt{65 \times 5 \times 15 \times 45} \\ &= \mathbf{468.4 \text{ cm}^2} \end{aligned}$$

$$\begin{aligned} \text{Area of polish on both sides} &= 2 \times 468.4 \\ &= 936.8 \text{ cm}^2 \end{aligned}$$

$$\text{Cost of polish per 100 cm}^2 = \text{Rs. } 1.35$$

$$\begin{aligned} \therefore \text{Cost of polish is } 936.8 \text{ cm}^2 &= \frac{936.8}{100} \times 1.35 \\ &= \text{Rs. } 12.65 \end{aligned}$$

- 10 Find the area of the right angled triangle with base 20 cm and height 8 cm.

$$\text{Base } b = 20 \text{ cm}$$

$$\begin{aligned} \text{Equal sides or} \\ \text{slant height} &= 8 \text{ cm} \end{aligned}$$

$$\text{Area (A)} = ?$$

$$\text{Area (A)} = \frac{1}{2} \times \text{base} \times \text{height unit}^2$$

$$= \frac{1}{2} \times 20 \times 8$$

$$= \mathbf{80 \text{ cm}^2}$$

- 11 Find the area of the right angled triangle if the sides containing the right angle being 10.5 cm and 8.2 cm.

$$\text{Area (A)} = \frac{1}{2} \times \text{base} \times \text{height unit}^2$$

$$= \frac{1}{2} \times 10.5 \times 8.2$$

$$= \mathbf{43.05 \text{ cm}^2}$$

- 12 Calculate the perpendicular height of the triangle if the area of the right angled triangle is 19.44 m<sup>2</sup> and its one of the adjacent side containing the right angle being 5.4 m.

$$\frac{1}{2} \times \text{base} \times \text{height unit}^2 = \text{Area}$$

$$\frac{1}{2} \times 5.4 \times h = 19.44$$

$$h = \frac{19.44 \times 2}{5.4}$$

$$= 7.2 \text{ m}$$

13 Calculate the base of a right angled triangle having an area of 12.5 cm<sup>2</sup>. If its height is 2.5 cm.

$$\frac{1}{2} \times \text{base} \times \text{height unit}^2 = \text{Area}$$

$$\frac{1}{2} \times b \times 2.5 = 12.5$$

$$b = \frac{12.5 \times 2}{2.5}$$

$$= 10 \text{ cm}$$

### Pythagoras theorem

In a right angled triangle the area of the square drawn with the hypotenuse as the side is equal to the sum of the areas of the squares drawn with the other two sides.

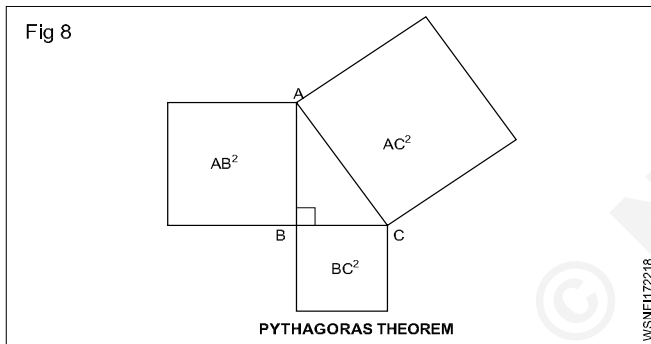

$$\angle B = 90^\circ$$

AC = Hypotenuse

AB & BC = Adjacent sides

As per pythagoras theorem,

$$AC^2 = AB^2 + BC^2$$

$$\therefore AC = \sqrt{AB^2 + BC^2}$$

1 Calculate the hypotenuse of a right angled triangle whose base is 5 cm and height is 12 cm.

As per pythagoras theorem,

$$AC^2 = AB^2 + BC^2$$

$$= 12^2 + 5^2$$

$$= 144 + 25$$

$$= 169$$

$$AC = \sqrt{169}$$

$$= 13 \text{ cm}$$

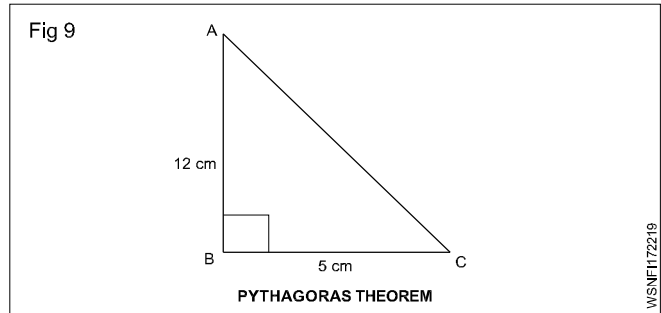

2 What is the length of the hypotenuse of a right angled triangle, when the sides containing the right angles are 10 cm and 12 cm.

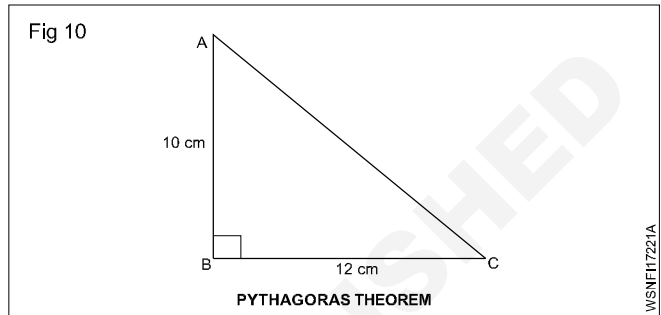

As per pythagoras theorem,

$$AC^2 = AB^2 + BC^2$$

$$= 10^2 + 12^2$$

$$= 100 + 144$$

$$= 244$$

$$AC = \sqrt{244}$$

$$= 15.62 \text{ cm}$$

3 Find the height of a right angled triangle whose base is 15 cm and hypotenuse is 21 cm.

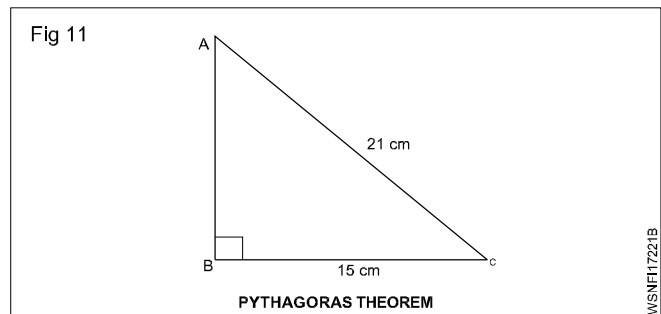

As per pythagoras theorem,

$$AB^2 + BC^2 = AC^2$$

$$AB^2 + 15^2 = 21^2$$

$$AB^2 = 441 - 225$$

$$= 216$$

$$AB = \sqrt{216}$$

$$= 14.7 \text{ cm}$$

Mensuration - Area and perimeter of circle, semi-circle, circular ring, sector of circle, hexagon and ellipse

Circle

It is the path of a point which is always equal from its centre is called a circle.

r = radius of the circle

d = diameter of the circle

$$\pi = \frac{22}{7} = 3.14$$

Area of the circle =  $\pi r^2$

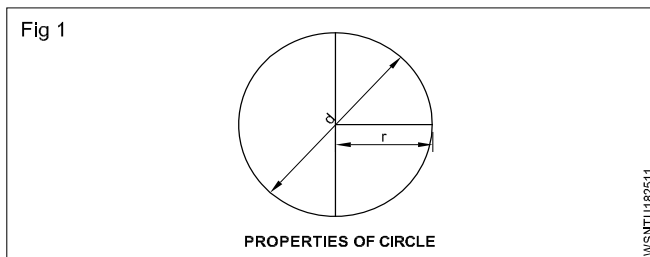

(or) 
$$= \frac{\pi}{4} d^2 \text{ unit}^2$$

Circumference of the circle  $2\pi r$  (or)  $\pi d$  unit

Examples

1 Find the area of a circle whose radius is 1.54 m. Also find its circumference.

radius r = 1.54 cm

Area A = ?

Circumference C = ?

$$A = \pi r^2 \text{ unit}^2$$

$$= \frac{22}{7} \times 1.54 \times 1.54$$

$$= 7.4536 \text{ m}^2$$

$$C = 2\pi r \text{ unit}$$

$$= 2 \times \frac{22}{7} \times 1.54$$

$$= 9.68 \text{ m}$$

2 Find out the circumference if the area of a circular shape of land is 616 m<sup>2</sup>.

A =  $\pi r^2$  unit<sup>2</sup>

$$r^2 = \frac{616}{\pi}$$

$$= \frac{616 \times 7}{22}$$

$$= 196$$

$$r = \sqrt{196}$$

$$= 14 \text{ m}$$

Circumference =  $2\pi r$  unit

$$= 2 \times \frac{22}{7} \times 14$$

$$= 88 \text{ m}$$

3 Find the side of square into which it can be bent if a wire is in the form of a circle of radius 49 cm.

radius of circle r = 49 cm

side of square = ?

Perimeter of the square = Perimeter of the circle

$$4a = 2\pi r$$

$$4a = 2 \times \frac{22}{7} \times 49$$

$$4a = 308$$

$$a = \frac{308}{4}$$

$$= 77 \text{ cm}$$

4 Find its radius if the difference between the circumference and diameter of a circle is 28 cm.

Circumference - Diameter = 28 cm

$$2\pi r - d = 28$$

$$2\pi r - 2r = 28$$

$$2r(\pi - 1) = 28$$

$$2r \left( \frac{22}{7} - 1 \right) = 28$$

$$2r \left( \frac{22-7}{7} \right) = 28$$

$$2r \times \frac{15}{7} = 28$$

$$r = \frac{28 \times 7}{15 \times 2}$$

$$= 6.53 \text{ cm}$$

- 5 What is the side of the largest square cut out from a circle of 50 cm dia.?

Diagonal of a square = Diameter of the circle

$$\sqrt{2}a = 50$$

$$a = \frac{50}{\sqrt{2}}$$

$$= \frac{50}{1.414}$$

$$= \mathbf{35.36 \text{ cm}}$$

- 6 Calculate the area of the figure given below.

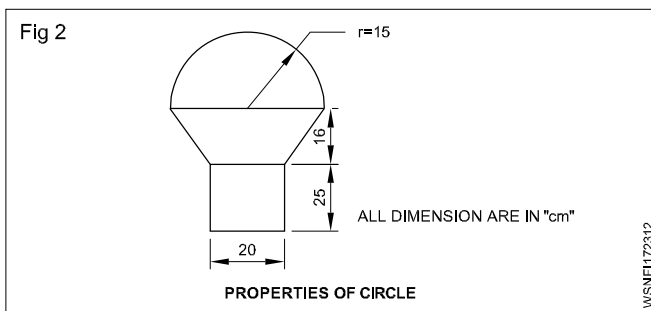

$$\begin{aligned} \text{Area of rectangle} &= lb \text{ unit}^2 \\ &= 25 \times 20 \text{ cm}^2 \\ &= 500 \text{ cm}^2 \end{aligned}$$

$$\begin{aligned} \text{Area of Trapezium} &= \frac{1}{2} \times (a + b) h \\ &= \frac{1}{2} \times (30 + 20) 16 \text{ cm}^2 \end{aligned}$$

$$\begin{aligned} &= \frac{1}{2} \times 50 \times 16 \text{ cm}^2 \\ &= 400 \text{ cm}^2 \end{aligned}$$

$$\begin{aligned} \text{Area of Semi circle} &= \frac{\pi r^2}{2} \text{ unit}^2 \\ &= \pi \times 15^2 \times \frac{1}{2} \text{ cm}^2 \\ &= 353.57 \text{ cm}^2 \end{aligned}$$

$$\begin{aligned} \text{Total area of the figure} &= 500 + 400 + 353.57 \\ &= \mathbf{1253.57 \text{ cm}^2} \end{aligned}$$

- 7 Find the area of remaining steel plate if in a rectangular steel plate 16 cm x 12 cm, there are 6 holes each 4 cm in diameter.

$$\begin{aligned} \text{Area of a rectangular plate} &= \text{length} \times \text{breadth} \text{ unit}^2 \\ &= 16 \times 12 \\ &= 192 \text{ cm}^2 \end{aligned}$$

$$\text{No. of holes} = 6$$

$$\text{Radius of hole} = 2 \text{ cm}$$

$$\begin{aligned} \text{Area of 6 holes} &= 6 \times \pi r^2 \text{ unit}^2 \\ &= 6 \times \frac{22}{7} \times 2 \times 2 \text{ unit}^2 \\ &= 75.43 \text{ cm}^2 \end{aligned}$$

$$\begin{aligned} \text{Area of remaining plate} &= 192 - 75.43 \\ &= \mathbf{116.57 \text{ cm}^2} \end{aligned}$$

## Semi circle

A semi circle is a sector whose central angle is 180°. Length of arc of semi circle.

$$\begin{aligned} \text{Length of arc} &= 2\pi r \times \frac{180}{360} \\ &= 2\pi r \times \frac{1}{2} = \pi r \text{ unit} \end{aligned}$$

$$\text{Area of semi circle} = \frac{\pi r^2}{2} \text{ Sq. units}$$

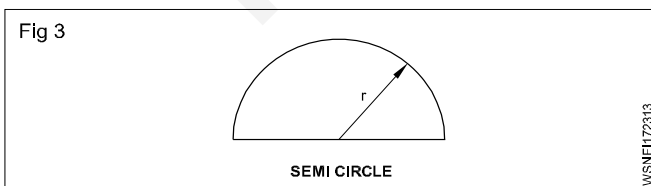

$$\begin{aligned} \text{Perimeter of a semi circle} &= \frac{2\pi r}{2} + 2r \\ &= \pi r + 2r \\ &= r(\pi + 2) \text{ unit} \end{aligned}$$

## Examples

- 1 Calculate the circumference and area of a semi circle whose radius is 6 cm.

$$\text{radius } r = 6 \text{ cm}$$

$$\text{Area } A = ?$$

$$\text{Circumference } c = ?$$

$$\begin{aligned} A &= \frac{\pi r^2}{2} \text{ unit}^2 \\ &= \frac{22}{7} \times \frac{1}{2} \times 6^2 \\ \text{Area (A)} &= \frac{22}{7} \times \frac{1}{2} \times 36 \\ &= \frac{396}{7} = 56.57 \text{ cm}^2 \end{aligned}$$

$$\text{Perimeter of a semicircle} = \frac{2\pi r}{2} + 2r = \pi r + 2r$$



$$\begin{aligned}
 &= r(\pi + 2) = 6 \left( \frac{22}{7} + 2 \right) \\
 &= 6 \left( \frac{22 + 14}{7} \right) \\
 &= 6 \times \frac{36}{7} \\
 &= \frac{216}{7} \\
 &= \mathbf{30.86 \text{ cm}}
 \end{aligned}$$

- 2 From the figure given below ABCD is a steel plate, a semi circular plate of radius 50 mm has been prepared by gas cutting. Find the waste area.

Plate length AB	= 100 mm
Breadth BC	= 50 mm
Radius	= 50 mm

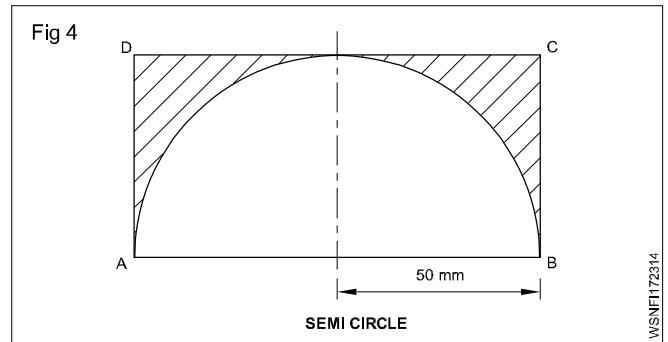

Waste area = Plate area - Area of semi circle

$$\begin{aligned}
 &= lb - \frac{\pi r^2}{2} \\
 &= 100 \times 50 - \frac{22 \times 50 \times 50}{7 \times 2} \\
 &= 5000 - 3928.57 \\
 &= \mathbf{1071.43 \text{ mm}^2}
 \end{aligned}$$

## Circular ring

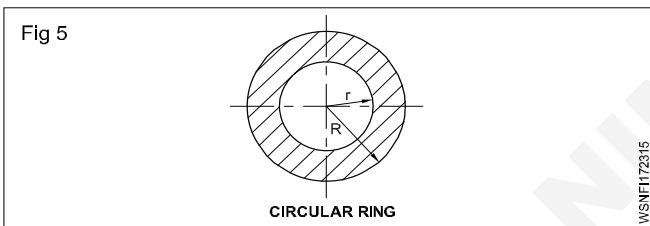

R = Outer radius of circular ring

r = Inner radius of circular ring

Area of circular ring =  $\pi (R^2 - r^2)$  unit<sup>2</sup>

or

A =  $\pi (R + r) (R - r)$  unit<sup>2</sup>

- 1 Calculate the area of cross section of pipe having outside dia of 17 cm and inside dia of 14 cm.

Given:

Outer dia of pipe = 17 cm

Outer radius of pipe (R) =  $\frac{17}{2} = 8.5$  cm

Inner dia of pipe = 14 cm

Inner radius of pipe (r) =  $\frac{14}{2} = 7$  cm

To find:

Area of cross section of pipe = ?

Solution:

$$\begin{aligned}
 \text{Area of cross section of pipe} &= \pi (R + r) (R - r) \text{ unit}^2 \\
 &= \pi (8.5 + 7) (8.5 - 7) \\
 &= \frac{22}{7} \times 15.5 \times 1.5 \text{ cm}^2 \\
 &= \mathbf{73 \text{ cm}^2}
 \end{aligned}$$

- 2 Find the distance between the boundaries and the area of the circular ring, if the circumference of two concentric circle are 134 cm and 90 cm.

Given:

Circumference of outer circle = 134 cm

Circumference of inner circle = 90 cm

To find:

Distance between the circles = ?

Area of circular ring = ?

Solution:

Circumference of outer circle = 134 cm

$$2\pi R = 134 \text{ cm}$$

$$R = \frac{134}{2\pi} = 21.32 \text{ cm}$$

Circumference of inner circle = 90 cm

$$2\pi r = 90 \text{ cm}$$

$$r = \frac{90}{2\pi} = 14.32 \text{ cm}$$

Distance between the circle = R - r

$$= 21.32 - 14.32 \text{ cm}$$

$$= 7 \text{ cm}$$

Area of circular ring =  $\pi (R + r) (R - r)$  unit<sup>2</sup>

$$= \pi (21.32 + 14.32) (21.32 - 14.32) \text{ cm}^2$$

$$= \frac{22}{7} \times 35.64 \times 7 \text{ cm}^2$$

$$= \mathbf{784.08 \text{ cm}^2}$$

3 A wire can be bend in the form of a circle of radius 56 cm. If it is bend in a form of a square, find the side.

Given:

$$\text{Radius of circle} = 56 \text{ cm}$$

To find:

$$\text{Side of square} = ?$$

Solution:

$$\text{Radius of circle} = 56 \text{ cm}$$

$$\text{Circumference of circle} = 2\pi r \text{ unit} = 2\pi \times 56 \text{ cm}$$

$$\text{Side of square} = x \text{ cm}$$

Wire can be bend from the form of round to square

$$\text{Perimeter of square} = \text{circumference of circle}$$

$$4 \times a = 352 \text{ cm}$$

$$a = \frac{352}{4} = 88 \text{ cm}$$

## Sector of Circle

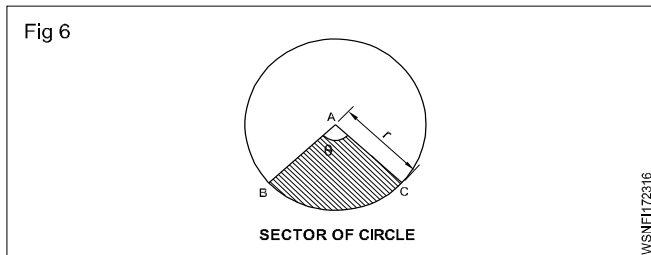

$\theta$  = Angle of sector of circle

$l$  = Arc length

$r$  = radius

$$\text{Length of Arc } l = \frac{\theta}{360^\circ} \times 2\pi r \text{ unit}$$

$$\text{Perimeter } P = 2r + l \text{ unit}$$

$$\text{Area} = \frac{\theta}{360^\circ} \times \pi r^2 \text{ unit}^2 \quad (\text{or}) \quad A = \frac{l r}{2} \text{ unit}^2$$

1 Find the perimeter and area of a sector of circle of radius 7 cm and its angle is  $120^\circ$ .

Given:

$$\text{Angle of sector of circle} = 120^\circ$$

$$\text{Radius} = 7 \text{ cm}$$

To find:

$$\text{Perimeter} = ? , \text{ Area} = ?$$

Solution:

$$\begin{aligned} \text{Length of arc } l &= \frac{\theta}{360^\circ} \times 2\pi r \text{ unit} \\ &= \frac{120}{360} \times 2 \times \frac{22}{7} \times 7 \text{ cm} \\ &= 14.67 \text{ cm} \end{aligned}$$

$$\begin{aligned} \text{Perimeter} &= 2r + l \text{ unit} \\ &= 2 \times 7 + 14.67 \text{ cm} \\ &= 28.67 \text{ cm} \end{aligned}$$

$$\text{Area} = \frac{\theta}{360^\circ} \times \pi r^2 \text{ unit}^2$$

$$\text{Area} = \frac{120^\circ}{360^\circ} \times \frac{22}{7} \times 7^2 \text{ cm}^2 = 51.33 \text{ cm}^2$$

2 Find the radius of the circle if the angle is  $60^\circ$  and the area of a sector of a circle is  $144 \text{ cm}^2$ ,

Given:

$$\text{Area of sector of circle } (A) = 144 \text{ cm}^2$$

$$\text{Angle of sector of circle } \theta = 60^\circ$$

To find:

$$\text{Radius of circle} = ?$$

Solution:

$$\text{Area } (A) = \frac{\theta}{360^\circ} \times \pi r^2 \text{ unit}^2$$

$$144 = \frac{60^\circ}{360^\circ} \times \frac{22}{7} \times r^2 \text{ cm}^2$$

$$r^2 = 274.91 \text{ cm}^2$$

$$r = \sqrt{274.91} = 16.58 \text{ cm}$$

3 Find the area of the sector whose angle is  $105^\circ$ , and the perimeter of sector of circle is 18.6 cm.

Given:

$$\text{Perimeter of a sector of a circle} = 18.6 \text{ cm}$$

$$\text{Angle of sector of circle} = 105^\circ$$

To find:

$$\text{Area} = ?$$

Solution:

$$\text{Length of Arc } l = \frac{\theta}{360^\circ} \times 2\pi r \text{ unit}$$

$$\begin{aligned} l &= \frac{105^\circ}{360^\circ} \times 2 \times \frac{22}{7} \times r \\ &= 1.83r \end{aligned}$$

$$\text{Perimeter } (P) = l + 2r \text{ unit}$$

$$18.6 = 1.83r + 2r$$

$$3.83r = 18.6 \text{ cm}$$

$$r = \frac{18.6}{3.83} = 4.86 \text{ cm}$$

$$\begin{aligned} \text{Area A} &= \frac{\theta}{360^\circ} \times \pi r^2 \text{ unit}^2 \\ &= \frac{105^\circ}{360^\circ} \times \frac{22}{7} \times (4.86) \text{ cm}^2 \\ &= 21.65 \text{ cm}^2 \end{aligned}$$

4 Find the area, if the radius is 12.4 cm and the perimeter of a sector of a circle is 64.8 cm.

Given:

$$\text{Perimeter P} = 64.8 \text{ cm}$$

$$\text{Radius } r = 12.4 \text{ cm}$$

To find:

$$\text{Area A} = ?$$

Solution:

$$\text{Perimeter P} = 2\sqrt{21} + 2r \text{ unit}$$

$$2\sqrt{21} = P - 2r \text{ unit}$$

$$= 64.8 - 2(12.4) \text{ cm}$$

$$= 64.8 - 24.8 = 40 \text{ cm}$$

$$\text{Area A} = \frac{lr}{2} \text{ unit}^2 = \frac{40 \times 12.4}{2}$$

$$= 248 \text{ cm}^2$$

5 Find out the length of the belt, if the arrangement of a belt is shown in the figure below.

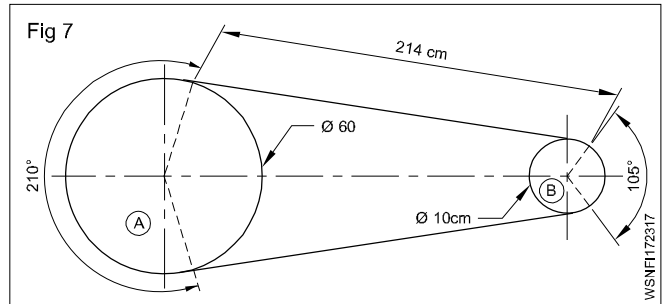

Solution:

$$\begin{aligned} \text{Length } 2\sqrt{21}_A &= \frac{\theta}{360^\circ} \times 2\pi r \text{ unit} \\ &= \frac{210^\circ}{360^\circ} \times 2 \times \frac{22}{7} \times 30 = 110 \text{ cm} \end{aligned}$$

$$\begin{aligned} \text{Length } 2\sqrt{21}_B &= \frac{\theta}{360^\circ} \times 2\pi r \text{ unit} \\ &= \frac{105^\circ}{360^\circ} \times 2 \times \frac{22}{7} \times 5 = 91.7 \text{ cm} \\ &= 2\sqrt{21}_A + 2\sqrt{21}_B + 2 \times 214 \text{ cm} \\ &= 110 + 91.7 + 428 \text{ cm} \\ &= 547.17 \text{ cm} \end{aligned}$$

## Hexagon

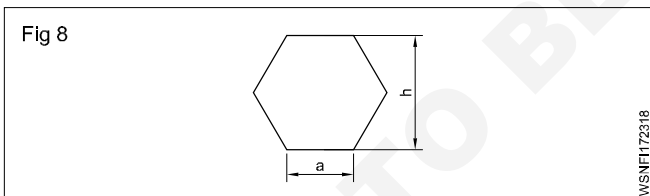

Side = a unit

Perimeter P = 6a unit

Area A =  $6 \times \frac{\sqrt{3}}{4} \times a^2$  units<sup>2</sup> (Area of 6 equilateral triangle)

DAF (Distance Across Flats) =  $\sqrt{3} \times a$  unit

DAC (Distance Across Corners) = 2 x a unit

1 Find out the perimeter, area, DAF and DAC of a regular hexagon whose side is 2cm.

(DAF - Distance Across Flats)

(DAC - Distance Across Corners)

Given: Side of hexagon (a) = 2cm

To Find: P = ?, A = ?, DAF = ?, DAC = ?

Solution:

$$\begin{aligned} \text{Perimeter of hexagon (P)} &= 6a \text{ unit} \\ &= 6a \text{ unit} = 6 \times 2 \text{ cm} = 12 \text{ cm} \end{aligned}$$

$$\begin{aligned} \text{Area of hexagon A} &= 6 \times \frac{\sqrt{3}}{4} \times a^2 \text{ unit}^2 \\ &= 6 \times \frac{1.732}{4} \times 2^2 \\ &= 10.392 \text{ cm}^2 \end{aligned}$$

$$\begin{aligned} \text{DAF (Distance Across Flats)} &= \sqrt{3} \times a \text{ unit} \\ &= \sqrt{3} \times 2 = 1.732 \times 2 \\ &= 3.464 \text{ cm} \end{aligned}$$

$$\begin{aligned} \text{DAC (Distance Across Corners)} &= 2 \times a \text{ unit} \\ &= 2 \times 2 = 4 \text{ cm} \end{aligned}$$

## Ellipse

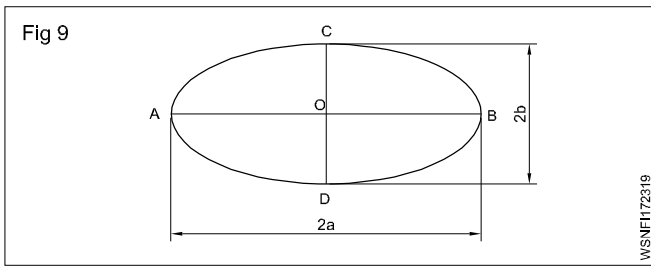

Major axis  $AB = 2a$

Half of Major axis  $OB = a$ ,

Minor axis  $CD = 2b$

Half of Minor axis  $OC = b$

Area of ellipse  $A = \pi \times a \times b \text{ unit}^2$

Perimeter of ellipse  $P = 2\pi \sqrt{\frac{a^2 + b^2}{2}} \text{ unit}$

- 1 Find its area and perimeter, if the major and minor axis of an ellipse are 12 cm and 8 cm respectively.

Solution:

$$\text{Major axis } 2a = 12 \text{ cm}$$

$$a = \frac{12}{2} = 6 \text{ cm}$$

$$\text{Minor axis } 2b = 8 \text{ cm}$$

$$b = \frac{8}{2} = 4 \text{ cm}$$

$$\text{Area } A = \pi \times a \times b \text{ unit}^2$$

$$= \frac{22}{7} \times 6 \times 4 \text{ cm}^2$$

$$= 75.43 \text{ cm}^2$$

$$\text{Perimeter (P)} = 2\pi \sqrt{\frac{a^2 + b^2}{2}} \text{ unit}$$

$$= 2 \times \frac{22}{7} \sqrt{\frac{6^2 + 4^2}{2}} \text{ unit}$$

$$= 2 \times \frac{22}{7} \sqrt{\frac{36 + 16}{2}} \text{ unit}$$

$$= 2 \times \frac{22}{7} \times \sqrt{26}$$

$$= 2 \times \frac{22}{7} \times 5.1 = 32.06 \text{ cm}$$

## Assignment

### Circle

- 1 Find the circumference and area of a circle whose radius is 10 metre.
- 2 Find its diameter if the area of a circle is  $330 \text{ cm}^2$ .
- 3 Find its area if the circumference of a circle is 50 cm.
- 4 Find out the area and circumference of a circle of diameter is 50 cm.
- 5 Find its area if the circumference of a circle is 44 cm.

### Semi circle

- 1 Calculate the circumference and area of semi circle whose radius is 14 cm.
- 2 Find area of the given figure.

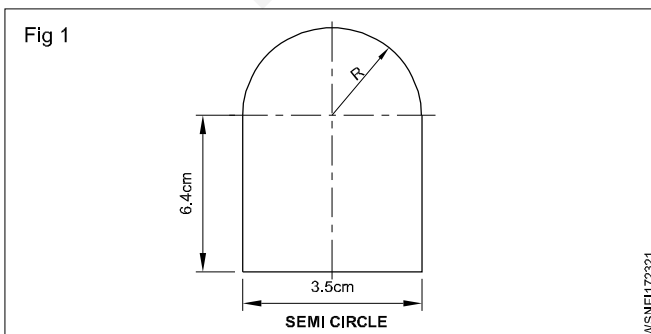

### Circular ring

- 1 Find out area of a ring washer, whose inner radius and outer radius are 13 cm and 15 cm respectively.
- 2 Find the area of a ring portion of a washer whose outer dis is 30 m and inner dis is 20 m. Also calculate the difference between the circumference of circles.

### Sector of circle

- 1 Find the perimeter and area of a sector of a circle of radius 5cm and its angle is  $96^\circ$ .
- 2 Find the radius of the circle if the angle is  $90^\circ$  and the area of sector of a circle is  $196 \text{ cm}^2$ .

### Hexagon

- 1 Find out the Area, perimeter, DAF, and DAC of hexagon of side 4cm.
- 2 Find the area of cross section of a regular hexagon rod whose side is 7.5 cm.

### Ellipse

- 1 Find the area of the biggest ellipse that can be inscribed in a rectangle of length 18 cm and breadth 12 cm. Also calculate its perimeter.
- 2 How much fencing will be required to enclose an elliptical plot of ground the axes of the ellipse being 200 and 170 meter respectively.

Mensuration - Surface area and volume of solids - cube, cuboid, cylinder, sphere and hollow cylinder

**Cube**

All sides of cube are same i.e length, breadth and height have same value. It is bounded by six equal square faces.

Volume of cube = side x side x side  
 =  $a^3 \text{ unit}^3$

Lateral surface area =  $4a^2 \text{ unit}^2$

Total surface area = 6 x side x side  
 =  $6a^2 \text{ unit}^2$        $\sqrt{3} = 1.732$

Diagonal d =  $\sqrt{3}a$

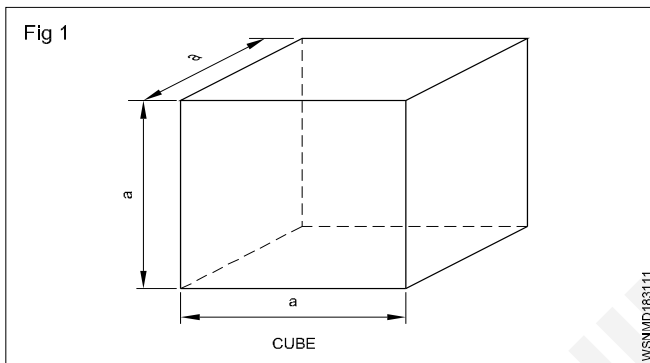

**Rectangular solid (or) cuboid**

Rectangular solid is bounded by six rectangular surfaces and opposite surfaces are equal and parallel to each other.

Volume of rectangular solid = Length x breadth x height  
 =  $l . b . h \text{ unit}^3$

Lateral surface area =  $2h(l+b) \text{ unit}^2$

Total surface area =  $2lb + 2bh + 2hl$   
 =  $2(lb+bh+hl) \text{ unit}^2$

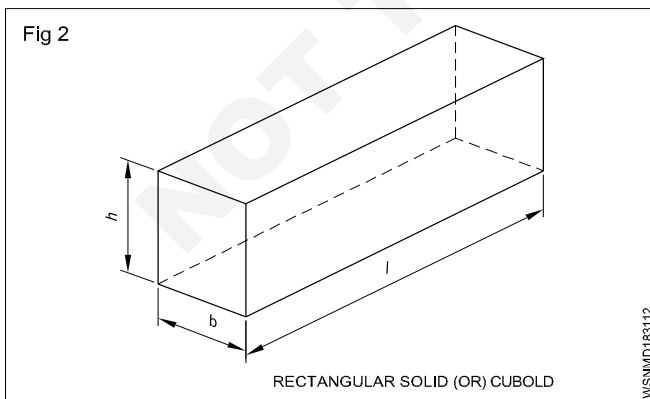

l = length, b = breadth and h = height

**Cylinder**

This is a prism whose top and bottom surfaces are equal and circular.

Volume of cylinder =  $\pi r^2 h$  or  $\frac{\pi}{4} d^2 h$

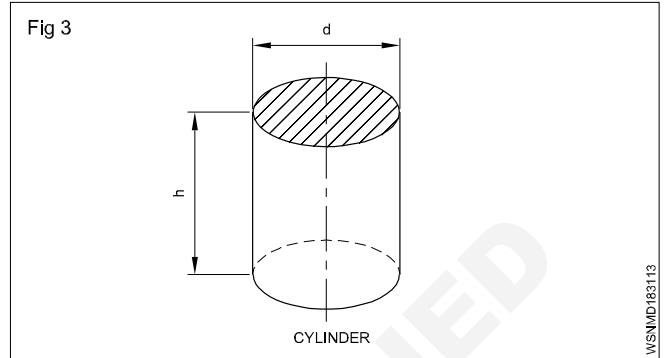

Curved area of cylinder =  $2\pi rh \text{ unit}^2$

Total surface area of cylinder =  $2\pi r(h+r) \text{ unit}^2$

r = Radius of base , d = Diameter of base

h = Height of cylinder

**Hollow cylinder**

Hollow means empty space. In hollow cylinder there is an empty place. Water pipe is an example of hollow cylinder.

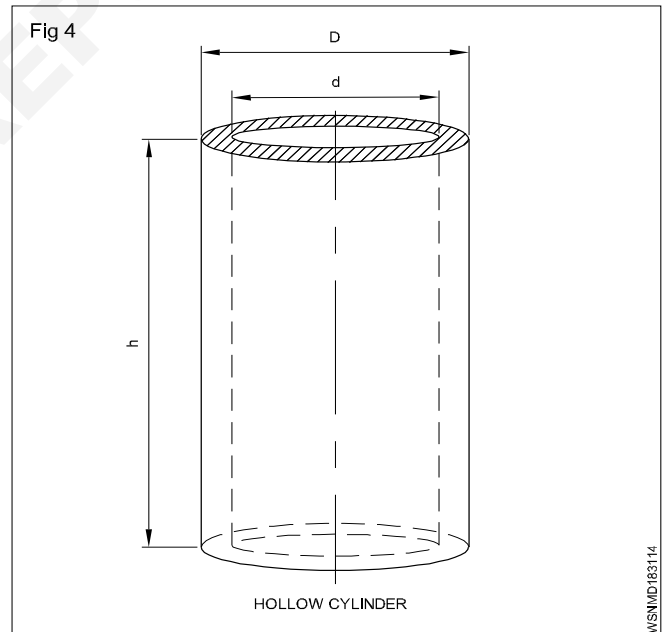

Volume of hollow cylinder =  $\pi (R^2 - r^2) h$  (or)  
 =  $\pi (R + r) (R - r) h$  (or)  
 =  $\frac{\pi}{4} (D^2 - d^2) h \text{ unit}^3$   
 =  $\frac{\pi}{4} (D + d)(D - d) h$

Total surface area of hollow cylinder =

Inner + outer curved area + area of top and bottom circular part

∴ TSA :  $2\pi Rh + 2\pi rh + 2\pi(R^2 - r^2)$

R = outer radius

r = inner radius

D = outer diameter

d = inner diameter

h = height of cylinder

t = thickness

$$\text{Mean dia} = \frac{D-d}{2}$$

If thickness given then:

Volume of hollow cylinder =  $\pi \times$  mean dia  $\times$  thickness  $\times$  height

### Finding out volumes of solids

The space occupied by a body is known its volume. The volume of a body indicates the capacity to hold substance in it.

The general form of Lateral surface area Total surface area and Volume is :

**Lateral surface area** = perimeter of the base  $\times$  height

**Total surface area** = LSA + 2 (base area )

**Volume** = Area of base  $\times$  height

Important and commonly used solids are described below one after another:

### Cube

1 Find the diagonal, lateral surface area,, total surface area and volume of a cube of side 4.5 cm.

$$\text{side } a = 4.5 \text{ cm}$$

$$\begin{aligned} \text{diagonal } d &= \sqrt{3}a \text{ unit} \\ &= 1.732 \times 4.5 \\ &= 7.794 \text{ cm} \end{aligned}$$

$$\begin{aligned} \text{L.S.A} &= 4a^2 \text{ unit}^2 \\ &= 4 \times 4.5 \times 4.5 \\ &= 81 \text{ cm}^2 \end{aligned}$$

$$\begin{aligned} \text{T.S.A} &= 6a^2 \text{ unit} \\ &= 6 \times 4.5 \times 4.5 \\ &= 121.5 \text{ cm}^2 \end{aligned}$$

$$\begin{aligned} V &= a^3 \text{ unit}^3 \\ &= 4.5 \times 4.5 \times 4.5 \\ &= \mathbf{91.125 \text{ cc.}} \end{aligned}$$

2 Calculate volume of a cube where side is 9 cm

$$a = 9 \text{ cm}$$

$$V = ?$$

$$\begin{aligned} V &= a^3 \\ &= 9 \times 9 \times 9 \\ &= \mathbf{729 \text{ cm}^3} \end{aligned}$$

3 Find out side of the cube if a cube has volume of 3375cm<sup>3</sup>.

$$V = 3375 \text{ cm}^3$$

$$a = ?$$

$$a^3 = 3375$$

$$a = \sqrt[3]{3375}$$

$$= \sqrt{3 \times 3 \times 3 \times 5 \times 5 \times 5}$$

$$= 3 \times 5$$

$$= \mathbf{15 \text{ cm}}$$

4 Find the side of a cube, if its surface area is 216 cm<sup>2</sup>

Surface area = T.S.A = 216 cm<sup>2</sup>

$$6a^2 = 216$$

$$a^2 = \frac{216}{6}$$

$$= 36$$

$$a = \sqrt{36}$$

$$= 6 \text{ cm}$$

5 Find the side of the square tank, if its height is 2 metre and has the capacity to hold 50,000 litre of water.

Height of square shape tank (h) = 2 m

$$\text{Capacity} = 50,000 \text{ litre}$$

$$1000 \text{ litre} = 1 \text{ m}^3$$

$$50,000 \text{ Litre} = \frac{50000}{1000}$$

$$= 50 \text{ m}^3$$

$$\text{Capacity of tank} = 50 \text{ m}^3$$

$$a^2 \times h = 50$$

$$a^2 \times 2 = 50$$

$$a^2 = \frac{50}{2} = 25 \text{ m}^2$$

$$a = \sqrt{25} = 5 \text{ m}$$

**Side of the square tank = 5 m**

### Rectangular Solid (or) Cuboid

1 Find its volume and T.S.A if a tank is 20 m long, 15 m broad and 12 m high.

$$l = 20 \text{ m}$$

$$b = 15 \text{ m}$$

$$h = 12 \text{ m}$$

$$v = ?$$

$$\text{T.S.A} = ?$$

$$\begin{aligned} \text{Volume } v &= lbh \text{ unit}^3 \\ &= 20 \times 15 \times 12 \\ &= 3600 \text{ m}^3 \end{aligned}$$

$$\begin{aligned} \text{T.S.A} &= 2(lb + bh + hl) \text{ unit}^2 \\ &= 2((20 \times 15) + (15 \times 12) + (20 \times 12)) \\ &= 2(300 + 180 + 240) \\ &= \mathbf{1440 \text{ m}^2} \end{aligned}$$

- 2 Find out its height if the cross section is 260 mm length and 180 mm wide rectangular and the capacity of a fuel tank is 10500 cm<sup>3</sup>.

$$\begin{aligned} l &= 260 \text{ mm} = 26 \text{ cm} \\ b &= 180 \text{ mm} = 18 \text{ cm} \\ v &= 10500 \text{ cm}^3 \\ h &= ? \end{aligned}$$

$$\begin{aligned} l.b.h &= \text{volume} \\ 26 \times 18 \times h &= 10500 \end{aligned}$$

$$\begin{aligned} h &= \frac{10500}{26 \times 18} \\ &= \mathbf{22.44 \text{ cm}} \end{aligned}$$

- 3 How many litres of water it can store if a water tank has the following dimensions length = 1 metre, width = 0.8 metre and height = 1.2 metre?

$$\begin{aligned} \text{Volume} &= l \times b \times h \text{ unit}^3 \\ &= 1 \times 0.8 \times 1.2 \\ &= 0.96 \text{ m}^3 \quad [1 \text{ m}^3 = 1000 \text{ litres}] \\ &= 0.96 \times 1000 \end{aligned}$$

**= 960 litres of water can store in the tank.**

- 4 Find its volume if the base of a prism is a rectangle having 5m length, 4m breadth and the height of the prism is 15m.

The base of prism is rectangle

$$\begin{aligned} \text{Area of base} &= \text{length} \times \text{breadth} \\ &= 5 \times 4 \\ &= 20 \text{ square m} \end{aligned}$$

$$\begin{aligned} \text{Volume of prism} &= \text{Area of base} \times \text{Height} \\ &= 20 \times 15 \\ &= \mathbf{300 \text{ cm}^3} \end{aligned}$$

### Cylinder

- 1 Find the volume and total surface are of a cylinder having 9cm diameter and 15 cm height.

$$\begin{aligned} \text{diameter} &= 9 \text{ cm} \\ \text{radius } r &= 4.5 \text{ cm} \\ \text{height } h &= 15 \text{ cm} \\ \text{Volume } V &= ? \end{aligned}$$

$$\begin{aligned} \text{T.S.A} &= ? \\ V &= \pi r^2 h \text{ unit}^3 \\ &= \frac{22}{7} \times 4.5 \times 4.5 \times 15 \\ &= 954.4 \text{ cm}^3 \\ \text{T.S.A} &= 2\pi r(h+r) \text{ unit}^2 \\ &= 2 \times \frac{22}{7} \times 4.5 (15 + 4.5) \\ &= 2 \times \frac{22}{7} \times 4.5 \times 19.5 \\ &= \mathbf{551.4 \text{ cm}^2} \end{aligned}$$

- 2 Calculate the radius if the curved surface area of a cylindrical roller is 48π cm<sup>2</sup> and the roller is 10 cm long

$$\begin{aligned} \text{C.S.A} &= 48\pi \text{ cm}^2 \\ \text{length} &= 10 \text{ cm} \\ \text{radius} &= ? \\ 2\pi r h &= 48\pi \\ 2 \times \pi \times r \times 10 &= 48\pi \\ r &= \frac{48 \times \pi}{2 \times \pi \times 10} \\ &= \mathbf{2.4 \text{ cm}} \end{aligned}$$

- 3 Find its radius if the volume of a cylinder is 5544 cm<sup>3</sup> and its height is 16 cm.

$$\begin{aligned} \pi r^2 h &= v \\ 3.14 \times r^2 \times 16 &= 5544 \\ r^2 &= \frac{5544}{3.14 \times 16} \\ r^2 &= \frac{5544}{50.24} \\ &= 110.35 \\ r &= \sqrt{110.35} \\ &= \mathbf{10.5 \text{ cm}} \end{aligned}$$

- 4 Find the diameter of the tank if the volume of a circular tank is 68.46 m<sup>3</sup>, its height is 2 m.

$$\begin{aligned} \pi r^2 h &= 68.46 \\ r^2 &= \frac{68.46}{3.14 \times 2} \\ r^2 &= 10.9 \\ r &= \sqrt{10.9} \\ &= 3.3 \text{ m} \\ \text{diameter} &= 2r \\ &= 2 \times 3.3 \\ &= \mathbf{6.6 \text{ m}} \end{aligned}$$

- 5 A cylindrical vessel is to be made of 3 metre long and 1.9994 metre diameter. Calculate its total surface area, if it is in a closed form on one end.

$$\begin{aligned} h &= 3\text{m} \\ d &= 1.9994\text{ m} \\ r &= 0.9997\text{ m} \end{aligned}$$

$$\begin{aligned} \text{T.S.A} &= \text{C.S.A} + \text{Base area} \\ &= 2\pi rh + \pi r^2 \\ &= \left(2 \times \frac{22}{7} \times 0.9997 \times 3\right) + \left(\frac{22}{7} \times 0.9997^2\right) \\ &= 18.85 + 3.14 \\ &= \mathbf{21.99\text{ m}^2} \end{aligned}$$

- 6 How many litres of water a cylinder of radius 75 cm and height 100 cm can hold.

$$\begin{aligned} V &= \pi r^2 h \text{ unit}^3 \\ &= 3.142 \times 75 \times 75 \times 100 \\ &= 1767375 \text{ cm}^3 \\ &= \frac{1767375}{1000} \quad [1000 \text{ cc} = 1 \text{ litre}] \\ &= \mathbf{1767.375 \text{ litres.}} \end{aligned}$$

- 7 Calculate the height of cylindrical tin if a closed rectangular box 40 cm long, 30 cm wide and 25 cm deep has the same volume as that of cylinder tin of radius 17.5 cm.

Volume of cylinder = Volume of rectangular box

$$\pi r^2 h = l \times b \times h$$

$$\frac{22}{7} \times 17.5 \times 17.5 \times h = 40 \times 30 \times 25$$

$$\begin{aligned} h &= \frac{40 \times 30 \times 25 \times 7}{22 \times 17.5 \times 17.5} \\ &= \frac{210000}{6737.5} \\ &= \mathbf{31.17 \text{ cm}} \end{aligned}$$

- 8 An oxygen cylinder is 15 cm in diameter and 100 cm in length. It is filled with gas under pressure so that every  $\text{cm}^3$  of the cylinder contains 120  $\text{cm}^3$  of gas. How much cc of oxygen does this hold?

$$\begin{aligned} \text{Volume of cylinder} &= \pi r^2 h \text{ unit}^3 \\ &= \frac{22}{7} \times 7.5 \times 7.5 \times 100 \\ &= 17678.57 \text{ cm}^3 \end{aligned}$$

Gas contain in 1  $\text{cm}^3 = 120 \text{ cm}^3$  of gas

$$\begin{aligned} \text{Gas contain in } 17678.57 \text{ cm}^3 &= 17678.57 \times 120 \\ &= 2121428 \text{ cm}^3 \end{aligned}$$

**Volume of oxygen = 2121428 cc.**

## Sphere

Sphere is a solid circular body.

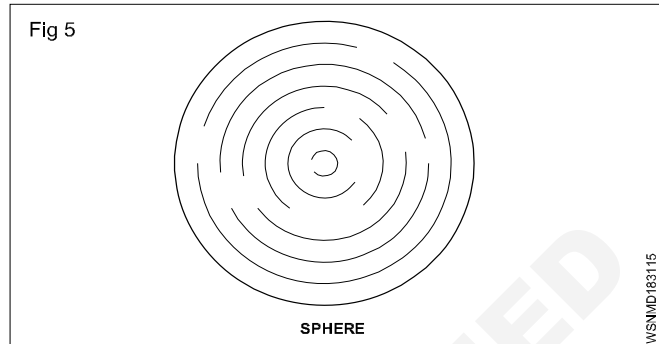

$$\begin{aligned} \text{Volume of sphere} &= \frac{4}{3} \pi r^3 \quad \text{or} \\ &= \frac{\pi}{6} d^3 \text{ unit}^3 \end{aligned}$$

Total surface area of sphere =  $4\pi r^2$  unit<sup>2</sup>

Where r = Radius of sphere

d = Diametre of sphere

Radius =  $\frac{1}{2}$  of diameter

- 1 Find the volume and surface area of a sphere of 3 cm radius.

$$\begin{aligned} V &= \frac{4}{3} \pi r^3 \text{ unit}^3 \\ &= \frac{4 \times 22 \times 3 \times 3 \times 3}{3 \times 7} \\ &= 113.1 \text{ cm}^3 \\ \text{Total Surface Area} &= 4\pi r^2 \text{ unit}^2 \\ &= 4 \times \frac{22}{7} \times 3 \times 3 \\ &= \mathbf{113.1 \text{ cm}^2} \end{aligned}$$

- 2 Find the diameter of sphere having volume of 15625 cc.

$$\begin{aligned} \frac{4}{3} \pi r^3 &= \text{Volume} \\ \frac{4}{3} \times \frac{22}{7} \times r^3 &= 15625 \\ r^3 &= \frac{15625 \times 3 \times 7}{4 \times 22} \end{aligned}$$



$$= \frac{328125}{88}$$

$$= 3728.69$$

$$r = \sqrt[3]{3728.69}$$

$$= 15.51 \text{ cm}$$

$$\text{diameter} = 2 \times \text{radius}$$

$$= 2 \times 15.51$$

$$= 31.02 \text{ cm}$$

- 3 How many spherical balls of 1 cm radius can be made from a sphere of 32 cm diameter.

No. of balls x volume of small sphere = Volume of bigger sphere

$$N \times \frac{4}{3} \pi r^3 = \frac{4}{3} \pi R^3$$

$$N \times \frac{4}{3} \pi \times 1^3 = \frac{4}{3} \pi \times R^3$$

$$N = 16 \times 16 \times 16$$

$$= 4096 \text{ balls}$$

- 4 Three brass balls of diameters 3 cm, 4 cm and 5 cm are melted and make into one solid ball, if there is no wastage. Find the diameter of the solid ball.

$$1^{\text{st}} \text{ ball } d_1 = 3 \text{ cm,}$$

$$r_1 = 1.5 \text{ cm}$$

$$2^{\text{nd}} \text{ ball } d_2 = 4 \text{ cm,}$$

$$r_2 = 2 \text{ cm}$$

$$3^{\text{rd}} \text{ ball } d_3 = 5 \text{ cm,}$$

$$r_3 = 2.5 \text{ cm}$$

$$\text{Diameter of new ball} = ?$$

Volume of new ball = Volume of 3 spherical balls

$$\frac{4}{3} \pi r^3 = \frac{4}{3} \pi r_1^3 + \frac{4}{3} \pi r_2^3 + \frac{4}{3} \pi r_3^3$$

$$\frac{4}{3} \pi r^3 = \frac{4}{3} \pi (1.5^3 + 2^3 + 2.5^3)$$

$$r^3 = 3.375 + 8 + 15.625$$

$$r^3 = 27$$

$$r = \sqrt[3]{27}$$

$$r = \sqrt[3]{3 \times 3 \times 3}$$

$$r = 3 \text{ cm}$$

$$\text{Diameter of the ball} = 2 \times r$$

$$= 2 \times 3$$

$$= 6 \text{ cm}$$

## Assignment

### Cube

- Find the diagonal, lateral surface area, total surface area and volume of cube, whose side is 15 cm.
- Find the volume of 10 cubes where each side is 5 cm.
- Find its volume if a solid cube has each of its sides 60 mm long.
- What is its side if the total surface area of a cube is 384 m<sup>2</sup>.

### Cuboid

- Find the volume of the tank in m<sup>3</sup>, if the length is 60 m, breadth 40 m and height 20 m.
- Find the volume of a C.I. casting of a rectangular block having 25 cm x 20 cm x 8 cm size.
- Calculate the total surface area of a box whose length, width and height are 120 cm, 50 cm and 60 cm respectively.
- Find the volume of the sheet if a brass sheet is of 25 cm square and 0.4 cm thick.

### Cylinder

- Find the curved surface area of cylinder whose diameter is 18 cm and height 34 cm?
- Find the total surface area of cylinder whose diameter is 24 cm and height 40 cm?
- Find out the volume of cylinder whose base is 10 cm radius and height is 40 cm?

### Sphere

- Find the volume of sphere having diameter 3.5cm?
- Find the total surface area of a sphere having radius 1.75 cm?
- How many spherical balls of 1 cm radius can be made from a sphere of 16 cm diameter.
- Three balls of diameter 2m, 4cm and 6 cm are melted and made into one solid ball. If there is no wastage, find the diameter of solid ball.

**Mensuration - Finding the lateral surface area, total surface area and capacity in litres of hexagonal, conical and cylindrical shaped vessels**

**Hexagonal bar**

Volume of Hexagonal bar = Area of hexagonal x height

Lateral surface area of hexagonal bar

$$= 6 \times \text{side of hexagon} \times \text{length of the bar}$$

or = 3.464 x length of the bar x flat of hexagon

Total surface area of hexagonal bar

$$= \text{lateral surface area} + (2 \times \text{area of hexagon})$$

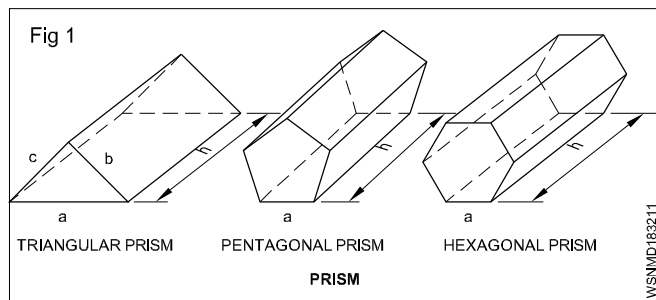

**Cone**

Cone is a pyramid with a circular base.

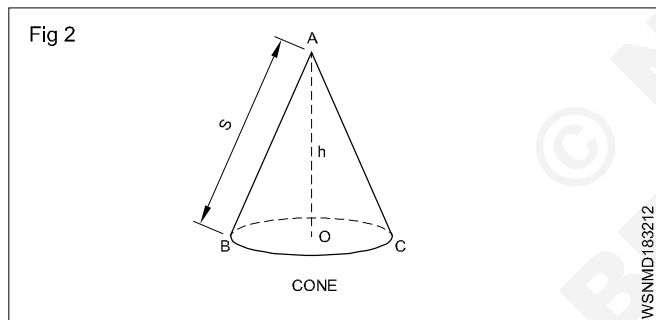

$$\text{Volume of cone} = \frac{1}{3} \pi r^2 h$$

$$\text{or} = \frac{\pi}{12} d^2 h$$

Curved area =  $\pi r s$

Total surface area =  $\pi r (s+r)$

Where r = radius of base

d = diameter of base

h = vertical height of cone

s = slant height  $\sqrt{r^2 + h^2}$

**Frustum of a cone**

When a cone is cut by a plane parallel to the base, and upper part is removed, the formation appears, is termed as frustum of a cone. Buckets, oil cans etc. are such frustums in shape.

$$\text{L.S.A} = \pi l (R + r) \text{ unit}^2$$

Fig 3

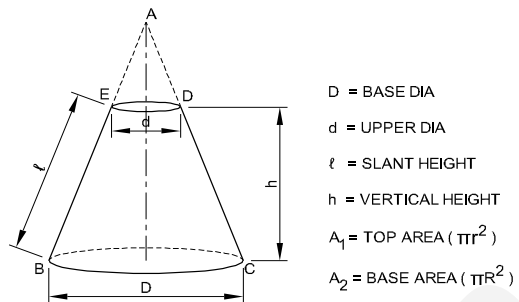

D = BASE DIA  
d = UPPER DIA  
l = SLANT HEIGHT  
h = VERTICAL HEIGHT  
 $A_1 = \text{TOP AREA} (\pi r^2)$   
 $A_2 = \text{BASE AREA} (\pi R^2)$

$$\text{TSA} = \pi l (R + r) + A_1 + A_2 \text{ unit}^2$$

$$V = \frac{\pi}{3} h (R^2 + Rr + r^2) \text{ unit}^3$$

[ $A_1$  = Top area ;  $A_2$  = Bottom area ]

**Cylinder**

This is a prism whose top and bottom surfaces are equal and circular.

$$\text{Volume of cylinder} = \pi r^2 h \text{ or } \frac{\pi}{4} d^2 h$$

Fig 4

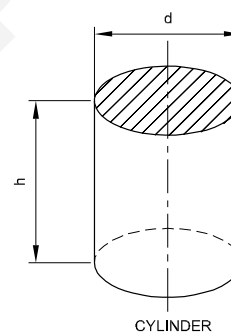

Curved area of cylinder =  $2\pi r h$

Total surface area of cylinder =  $2\pi r (h+r)$

r = Radius of base, d = Diameter of base

h = Height of cylinder

**Hollow cylinder**

Hollow means empty space. In hollow cylinder there is an empty place. Water pipe is an example of hollow cylinder.

$$\begin{aligned} \text{Volume of hollow cylinder} &= \pi (R^2 - r^2) h \text{ (or)} \\ &= \pi (R + r) (R - r) h \text{ (or)} \\ &= \frac{\pi}{4} (D^2 - d^2) h \\ &= \frac{\pi}{4} (D + d)(D - d) h \end{aligned}$$

Total surface area of hollow cylinder =

Inner + outer curved area + area of top and bottom circular part

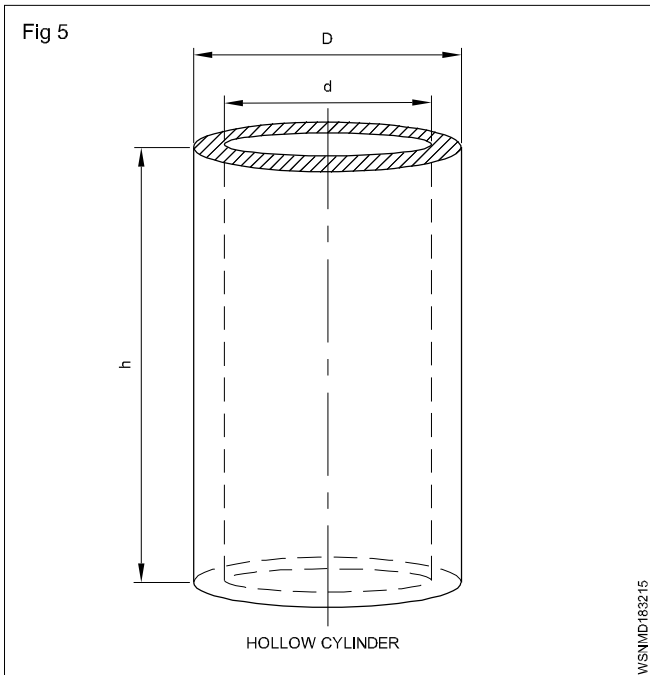

$$\therefore \text{TSA} : 2\pi Rh + 2\pi rh + 2\pi(R^2 - r^2)$$

R = outer radius

r = inner radius

D = outer diameter

d = inner diameter

h = height of cylinder

t = thickness

$$\text{Mean dia} = \frac{D-d}{2}$$

If thickness given then:

$$\text{Volume of hollow cylinder} = \pi \times \text{mean dia} \times \text{thickness} \times \text{height}$$

### Example

**1 Find the volume of an hexagonal prism having its side 20 cm and height 200 cm.**

$$\text{Side of hexagonal prism (a)} = 20 \text{ cm}$$

$$\text{Height (h)} = 200 \text{ cm}$$

$$\text{Volume (V)} = \text{Base side area} \times \text{Height}$$

$$= 6 \times \frac{\sqrt{3}}{4} \times a^2 \times h$$

$$= 6 \times \frac{\sqrt{3}}{4} \times 20 \times 20 \times 200$$

$$= 1,20,000 \times \sqrt{3}$$

$$= 1,20,000 \times 1.732$$

$$= \mathbf{2,07,840 \text{ cm}^3}$$

$$\text{Volume of the hexagonal prism} = \mathbf{2,07,840 \text{ cm}^3}$$

**2 Calculate the height. Also find the lateral surface area if a cone has a base diameter of 210 mm and its volume is 3056 cm<sup>3</sup>.**

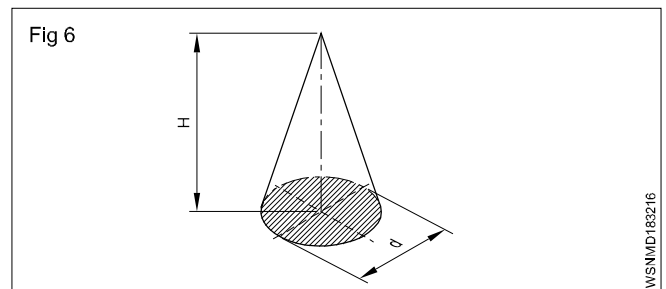

$$\text{Volume of a cone} = \frac{1}{3} \times \text{Area of base} \times \text{height}$$

$$3056 \text{ cm}^3 = \frac{1}{3} \times 0.785 \times 210^2 \text{ mm}^2 \times H$$

$$H = \frac{3056 \times 3 \times 1000 \text{ mm}^3}{0.785 \times 210^2 \text{ mm}^2} = 264.82 \text{ mm}$$

$$L = \text{Slant height} = \sqrt{264.82^2 + 105^2} = 284.9 \text{ mm}$$

$$\text{Lateral surface area} = \frac{1}{2} \pi \times 210 \times 284.9 \text{ mm}^2$$

$$= \mathbf{94017 \text{ mm}^2 = 940.17 \text{ cm}^2}$$

**3 Determine its diameter in mm if the height of a rod of 1.6 metres and its volume is 1.017 metre<sup>3</sup>.**

$$V = A \times H$$

$$V = \pi r^2 \times h \text{ (or) } \frac{\pi d^2}{4} \times h$$

$$\text{Volume} = \text{Area} \times \text{Height}$$

$$= \frac{\pi d^2}{4} = 0.785 d^2$$

$$1.017 \text{ m}^3 = 0.785 d^2 \times 1.6 \text{ metres}$$

$$0.785 d^2 = \frac{1.017}{1.6} \text{ m}^2$$

$$d^2 = \frac{1.017}{1.6 \times 0.785} \text{ m}^2$$

$$= \frac{1.017}{1.6 \times 785} \text{ m}^2$$

$$d = \sqrt{\frac{10170}{16 \times 785}} \text{ metre}$$

$$= \sqrt{\frac{10170}{12560}}$$

$$= \sqrt{0.8097}$$

$$= 0.8998$$

$$= \mathbf{899.8 \text{ mm}}$$

## Trigonometry - Measurement of angles

### Introduction:

Trigonometry is the branch of mathematics which deals with the study of measurement and relationship of the three sides and three angles of a triangle.

### Units:

#### Measurement of Angles

There are three systems of measuring the angle:

##### (i) Sexagesimal System

This is called British System. In this system, one right angle is divided into 90 equal parts which are called degrees. Each part is divided into 60 parts which are called minutes. Each minute is divided into 60 parts which are called seconds. The parts so divided respectively are called:

One degree ( $1^\circ$ ), one minute ( $1'$ ) and one second ( $1''$ )

It means 1 right angle =  $90^\circ$  (90 degrees)

1 degree ( $1^\circ$ ) =  $60'$  (60 minutes)

1 minute ( $1'$ ) =  $60''$  (60 seconds)

In Trigonometry, mostly this system is used.

##### (ii) Centesimal System

This is called French System. In this system, the right angle is divided into 100 equal parts which are called grades. Each grade is divided into 100 minutes and each minute is divided into 100 seconds.

Parts so divided are respectively called:

One grade (1 g), one minute ( $1'$ ), one second ( $1''$ ).

It means 1 right angle = 100 grades (100g)

1 grade (1 g) = 100 minutes ( $100'$ )

1 minute ( $1'$ ) = 100 seconds ( $100''$ )

$90^\circ = 100g$  (because each is a right angle)

This system is easier than Sexagesimal System. But to use this system many other systems will have to be devised that is why this system is not used.

##### (iii) Circular System

In this system, the unit of measuring angles is radian. It is that angle which is formed at the centre and is formed of an arc of length equal to radius in a circle.

There is one constant ratio between the circumference and dia of a circle. This is represented by  $\pi$ .

$$\frac{\text{Circumference}}{\text{Diameter}} = \text{constant point} = \pi$$

$$\begin{aligned} \text{Circumference} &= \pi \times \text{dia} \\ &= 2\pi r \text{ (where } r \text{ is radius of the circle)} \end{aligned}$$

$$\pi = \frac{22}{7}$$

Circumference makes an angle ( $2\pi r$ ) =  $360^\circ$

Radius of the circle makes an angle ( $r$ ) = 1 Radian

$$\text{ie : } \frac{C}{r} = \frac{360^\circ}{1\text{Radian}}$$

$$\frac{2\pi r}{r} = \frac{360^\circ}{1\text{Radian}}$$

$$2\pi = \frac{360^\circ}{1\text{Radian}}$$

$$2\pi \text{ Radian} = 360^\circ$$

$$\pi \text{ Radian} = 180^\circ$$

$$1 \text{ Radian} = \frac{180^\circ}{\pi}$$

$$1^\circ = \frac{\pi}{180^\circ} \text{ Radian}$$

### Examples

1 Convert  $45^\circ 36' 20''$  into degree and decimal of degree.

$$60 \text{ seconds} = 1 \text{ minute}$$

$$20 \text{ seconds} = \frac{20}{60} = 0.333'$$

$$60 \text{ minutes} = 1 \text{ degree}$$

$$36.333 \text{ minutes} = \frac{36.333}{60} = 0.606^\circ$$

$$45^\circ 36' 20'' = 45.606^\circ$$

2 Convert  $24.59^\circ$  into degree, minute and second

$$1 \text{ degree} = 60 \text{ minutes}$$

$$0.59 \text{ degree} = 0.59 \times 60 = 35.4'$$

$$1 \text{ minute} = 60 \text{ seconds}$$

$$0.4 \text{ minute} = 60 \text{ sec} \times 0.4$$

$$= 24''$$

$$\text{Therefore } 24.59^\circ = 24^\circ 35' 24''$$

3 Change  $50^\circ 37' 30''$  into degrees

By changing angle degrees into decimals

$$30'' = \frac{30}{60} = 0.50'$$

$$37' 30'' = 37.5'$$

$$37.5' = \frac{37.5}{60} = 0.625^\circ$$

$$50^\circ 37' 30'' = 50.625^\circ$$

4 Convert 23°25'32" into radians

We know 1° = 60' = 3600"

Therefore 23°25'32"

$$= \left( 23 + \frac{25}{60} + \frac{32}{3600} \right) \text{ degrees}$$

$$= \frac{82800 + 1500 + 32}{3600}$$

$$= \frac{84332}{3600}$$

But 180° = π radians

Therefore 23.4255 degrees

$$= \frac{23.4255}{180} \pi \text{ radians}$$

$$= \frac{23.4255}{180} \times \frac{22}{7} \text{ radians}$$

$$= \mathbf{0.4089 \text{ radians}}$$

5 Convert 87°19'57" into Radian.

$$19'57'' = 19' + \frac{57''}{60}$$

$$= 19' + 0.95'$$

$$= 19.95'$$

$$87^\circ 19.95' = 87^\circ + \frac{19.95'}{60}$$

$$= 87^\circ + 0.332^\circ = 87.33^\circ$$

$$1^\circ = \frac{\pi}{180} \text{ radian}$$

$$87.33^\circ = \frac{\pi}{180} \times 87.33 \text{ radian}$$

$$= 1.524 \text{ radian}$$

6 Convert 67°11'43" into Radian

$$11'43'' = 11' + \frac{43''}{60}$$

$$= 11' + 0.716'$$

$$= 11.72'$$

$$67^\circ 11.72' = 67^\circ + \frac{11.72'}{60}$$

$$= 67^\circ + 0.195^\circ$$

$$= 67.2^\circ$$

$$1^\circ = \frac{\pi}{180} \text{ radian}$$

$$67.2^\circ = \frac{\pi}{180} \times 67.2 \text{ radian}$$

$$= 1.173 \text{ radian}$$

7 Convert  $\frac{4}{7}\pi$  radian into degrees

$$1 \text{ radian} = \frac{180}{\pi} \text{ degree}$$

$$\frac{4}{7}\pi \text{ radian} = \frac{180}{\pi} \times \frac{4}{7} \pi \text{ degree}$$

$$= 102.9 \text{ degree}$$

$$= 102^\circ 0.9 \times 60'$$

$$= 102^\circ 54'$$

8 Convert 0.8357 radian into degrees

$$1 \text{ radian} = \frac{180}{\pi} \text{ degree}$$

$$0.8357 \text{ radian} = \frac{180}{\pi} \times 0.8357 \text{ degree}$$

$$= 47.88^\circ$$

$$= 47^\circ 0.88 \times 60'$$

$$= 47^\circ 52.80'$$

$$= 47^\circ 52' 0.8 \times 60''$$

$$= 47^\circ 52' 48''$$

9 Convert 2.752 radian into degrees

$$1 \text{ Radian} = \frac{180}{\pi} \text{ degree}$$

$$2.7520 \text{ radian} = \frac{180}{\pi} \times 2.752 \text{ degree}$$

$$= 157.7^\circ$$

$$= 157.7^\circ \times 60'$$

$$= 157^\circ 42'$$

10 Convert  $\frac{3}{5}\pi$  radian into degrees

$$1 \text{ Radian} = \frac{180}{\pi} \text{ degree}$$

$$\frac{3}{5}\pi \text{ radian} = \frac{180}{\pi} \times \frac{3}{5} \pi \text{ degree}$$

$$= 108^\circ$$

## Assignment

### Convert into Degree

1 12 Radian

### Convert into Radians

2 78°

3 47°20'

4 52°36'45"

5 25°38"

### Convert into degree, minute and seconds

6 46.723°

7 68.625°

8 0.1269 Radian

9 2.625 Radians

10 3/5 Radian

Trigonometry - Trigonometrical ratios

Dependency

The sides of a triangle bear constant ratios for a given definite value of the angle. That is, increase or decrease in the length of the sides will not affect the ratio between them unless the angle is changed. These ratios are trigonometrical ratios. For the given values of the angle a value of the ratios

$\frac{BC}{AB}$ ,  $\frac{AC}{AB}$ ,  $\frac{BC}{AC}$ ,  $\frac{AB}{BC}$ ,  $\frac{AB}{AC}$  and  $\frac{AC}{BC}$  do not change even when the sides AB, BC, AC are increased to AB', BC' and AC' or decreased to AB'', BC'' and AC''.

For the angle

AC is the hypotenuse

AB is the adjacent side

BC is the opposite side.

The ratios

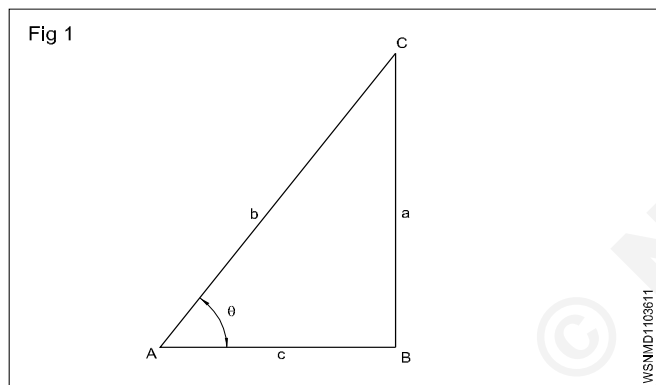

The six ratios between the sides have precise definitions.

$$\text{Sine } \theta = \frac{BC}{AC} = \frac{\text{Opposite side}}{\text{Hypotenuse}} = \text{Sin } \theta$$

$$\text{Cosine } \theta = \frac{AB}{AC} = \frac{\text{Adjacent side}}{\text{Hypotenuse}} = \text{Cos } \theta$$

$$\text{Tangent } \theta = \frac{BC}{AB} = \frac{\text{Opposite side}}{\text{Adjacent side}} = \text{Tan } \theta$$

$$\text{Cosecant } \theta = \frac{AC}{BC} = \frac{\text{Hypotenuse}}{\text{Opposite side}} = \text{Cosec } \theta$$

$$\text{Secant } \theta = \frac{AC}{AB} = \frac{\text{Hypotenuse}}{\text{Adjacent side}} = \text{Sec } \theta$$

$$\text{Cotangent } \theta = \frac{AB}{BC} = \frac{\text{Adjacent side}}{\text{Opposite side}} = \text{Cot } \theta$$

Relationship between the ratios

$$\text{Cosec } \theta = \frac{AC}{BC} = \frac{1}{\frac{BC}{AC}} = \frac{1}{\text{sin } \theta}$$

$$\text{sec } \theta = \frac{AC}{AB} = \frac{1}{\frac{AB}{AC}} = \frac{1}{\text{cos } \theta}$$

$$\text{cot } \theta = \frac{AB}{BC} = \frac{1}{\frac{BC}{AB}} = \frac{1}{\text{tan } \theta}$$

$$\text{sin } \theta = \frac{\text{side BC}}{\text{side AC}} = \frac{a}{b}$$

$$\text{cos } \theta = \frac{\text{side AB}}{\text{side AC}} = \frac{c}{b}$$

$$\frac{\text{sin } \theta}{\text{cos } \theta} = \frac{\frac{a}{b}}{\frac{c}{b}} = \frac{a}{b} \times \frac{b}{c} = \frac{a}{c}$$

$$= \frac{\text{side BC}}{\text{side AB}} = \text{tan } \theta$$

$$\text{sin } \theta = \frac{1}{\text{cosec } \theta} \text{ or } \text{cosec } \theta = \frac{1}{\text{sin } \theta} \text{ or } \text{sin } \theta \cdot \text{cosec } \theta = 1$$

$$\text{cos } \theta = \frac{1}{\text{sec } \theta} \text{ or } \text{sec } \theta = \frac{1}{\text{cos } \theta} \text{ or } \text{cos } \theta \cdot \text{sec } \theta = 1$$

$$\text{tan } \theta = \frac{1}{\text{cot } \theta} \text{ or } \text{cot } \theta = \frac{1}{\text{tan } \theta} \text{ or } \text{cot } \theta \cdot \text{tan } \theta = 1$$

By pythagoras theorem we have,  $AC^2 = AB^2 + BC^2$

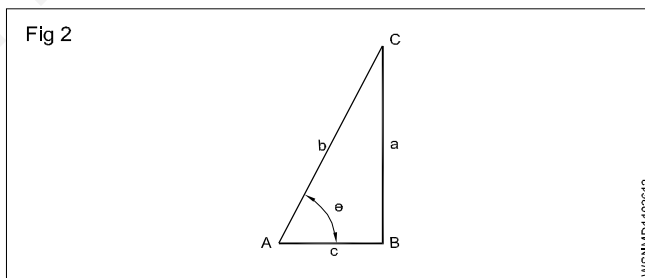

Dividing both sides of the equation by  $AC^2$ , we have

$$\frac{AC^2}{AC^2} = \frac{AB^2}{AC^2} + \frac{BC^2}{AC^2}$$

$$= \left[ \frac{AB}{AC} \right]^2 + \left[ \frac{BC}{AC} \right]^2$$

$$1 = (\text{cos } \theta)^2 + (\text{sin } \theta)^2$$

$$\text{sin}^2 \theta + \text{cos}^2 \theta = 1$$

**Sine, Cosine, Tangent, Cosec, Sec and Cotangent are the six trigonometrical ratios**

$$\text{tan } \theta = \frac{\text{Sin } \theta}{\text{Cos } \theta} \text{ and } \text{sin}^2 \theta + \text{cos}^2 \theta = 1$$

$$\sin^2 \theta + \cos^2 \theta = 1$$

It can be transformed as

$$\sin^2 \theta = 1 - \cos^2 \theta$$

$$\sin \theta = \sqrt{1 - \cos^2 \theta}$$

$$\text{or } \cos^2 \theta = 1 - \sin^2 \theta$$

$$\cos \theta = \sqrt{1 - \sin^2 \theta}$$

$$\tan \theta = \frac{\sin \theta}{\cos \theta} = \frac{\sqrt{1 - \cos^2 \theta}}{\cos \theta}$$

$$\tan \theta = \frac{\sin \theta}{\sqrt{1 - \sin^2 \theta}}$$

We know  $\sin^2 \theta + \cos^2 \theta = 1$

Dividing both sides by  $\cos^2 \theta$ .

$$\frac{\sin^2 \theta}{\cos^2 \theta} + \frac{\cos^2 \theta}{\cos^2 \theta} = \frac{1}{\cos^2 \theta}$$

$$\text{or } 1 + \tan^2 \theta = \sec^2 \theta$$

Using the same equation

$$\sin^2 \theta + \cos^2 \theta = 1.$$

Dividing both sides by  $\sin^2 \theta$ ,

$$\frac{\sin^2 \theta}{\sin^2 \theta} + \frac{\cos^2 \theta}{\sin^2 \theta} = \frac{1}{\sin^2 \theta}$$

$$1 + \frac{\cos^2 \theta}{\sin^2 \theta} = \frac{1}{\sin^2 \theta}$$

$$1 + \cot^2 \theta = \text{cosec}^2 \theta$$

$$1 + \tan^2 \theta = \sec^2 \theta$$

### Trigonometrical Tables

Ratio	0°	30°	45°	60°	90°
sin θ	0	$\frac{1}{2}$	$\frac{1}{\sqrt{2}}$	$\frac{\sqrt{3}}{2}$	1
cos θ	1	$\frac{\sqrt{3}}{2}$	$\frac{1}{\sqrt{2}}$	$\frac{1}{2}$	0
tan θ	0	$\frac{1}{\sqrt{3}}$	1	$\sqrt{3}$	∞

**When θ increases,**

**Sine value increases;**

**Cosine value decreases;**

**Tangent value increases to more than 1 when the angle is more than 45° ( $\tan 60^\circ = 1.732$ )**

**Sine of an angle = Cosine of its complementary angle**

**Cosine of an angle = Sine of its complementary angle**

### Examples

If  $\sin 30^\circ = \frac{1}{2}$  find the value of  $\sin 60^\circ$

By applying pythagores theorem

Fig 3

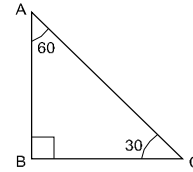

$$BC^2 = AC^2 - AB^2$$

$$BC^2 = 2^2 - 1^2$$

$$= 4 - 1$$

$$= 3$$

$$BC = \sqrt{3}$$

$$\sin 60^\circ = \frac{\sqrt{3}}{2}$$

$\cos \theta = \frac{3}{5}$  Find the other trigonometrical ratios

By applying pythagores theorem

$$AB^2 = AC^2 - BC^2$$

$$= 5^2 - 3^2 = 25 - 9$$

$$= 16$$

Fig 4

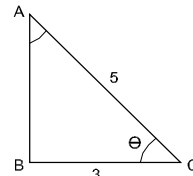

$$AB = \sqrt{16} = 4$$

$$\text{Now } \sin \theta = \frac{4}{5}$$

$$\tan \theta = \frac{4}{3}$$

$$\text{Cosec } \theta = \frac{5}{4}$$

$$\sec \theta = \frac{5}{3}$$

$$\cot \theta = \frac{3}{4}$$

## Signs of trigonometrical functions for angles more than 90°

Ratio	90 - θ	90 + θ	180 - θ	180 + θ	270 - θ	270 + θ	360 - θ	- θ
sin	cos	cos	sin	- sin	- cos	- cos	- sin	- sin
cos	sin	- sin	- cos	- cos	- sin	sin	cos	cos
tan	cot	- cot	- tan	tan	cot	- cot	- tan	- tan
cosec	sec	sec	cosec	- cosec	- sec	- sec	- cosec	- cosec
sec	cosec	- cosec	- sec	- sec	- cosec	cosec	sec	sec
cot	tan	- tan	- cot	cot	tan	- tan	- cot	- cot

**Simplify :**

$$\begin{aligned} \cot \theta + \tan (180+\theta) + \tan(90-\theta) + (\tan 360 - \theta) \\ = \cot \theta + \tan \theta - \cot \theta - \tan \theta \\ = 0 \end{aligned}$$

**Simplify :**

$$\begin{aligned} \frac{\cos (90+\theta) \sec (-\theta) \tan (180-\theta)}{\sec (360-\theta) \sin (180+\theta) \cos (90-\theta)} \\ = \frac{(-\sin \theta) \times (\sec \theta) \times (-\tan \theta)}{(\sec \theta) \times (-\sin \theta) \times (-\sin \theta)} \\ = \frac{\tan \theta}{\sin \theta} = \frac{1}{\cos \theta} = \sec \theta \end{aligned}$$

**simplify:**

$$\begin{aligned} \frac{\cos (90^{\circ}+\theta) \sec (-\theta) \tan (180^{\circ}-\theta)}{\sec (360^{\circ}-\theta) \sin (180^{\circ}+\theta) \cot (90^{\circ}-\theta)} \\ \cos (90^{\circ}+\theta) = -\sin \theta \\ \sec (-\theta) = \sec \theta \\ \tan (180^{\circ}-\theta) = -\tan \theta \end{aligned}$$

## Assignment

- Given  $\sin 30^{\circ} = 1/2$ , find the value of  $\tan 60^{\circ}$
- If  $\cos \theta = 4/5$ , find the other ratios
- If  $\sin A = 3/5$ , find  $\cos \theta$ ,  $\tan \theta$  &  $\sec \theta$
- If  $\tan \theta = 24/7$ , find  $\sin \theta$  and  $\cos \theta$
- Find the value of  $\cos \theta$  and  $\tan \theta$ , if  $\sin \theta = 1/2$
- If  $\cos \theta = 5/13$ , find the value of  $\tan \theta$
- If  $\sin \theta = 1/2$ , find the value of  $\sin^2 \theta - \cos^2 \theta$

$$\sec (360^{\circ}-\theta) = \sec \theta$$

$$\sin (180^{\circ}+\theta) = -\sin \theta$$

$$\cot (90^{\circ}+\theta) = -\tan \theta$$

$$\begin{aligned} \frac{\cos (90^{\circ}+\theta) \sec (-\theta) \tan (180^{\circ}-\theta)}{\sec (360^{\circ}-\theta) \sin (180^{\circ}+\theta) \cot (90^{\circ}-\theta)} \\ = \frac{(-\sin \theta)(\sec \theta)(\tan \theta)}{(\sec \theta)(-\sin \theta)(-\tan \theta)} \\ = 1 \end{aligned}$$

**Simplify:**

$$\begin{aligned} \cot \theta + \tan (180^{\circ}+\theta) + \tan (90^{\circ}+\theta) + \tan (360^{\circ}-\theta) \\ \tan (180^{\circ}-\theta) = \tan \theta \\ \tan (90^{\circ}+\theta) = -\cot \theta \\ \tan (360^{\circ}-\theta) = -\tan \theta \\ \cot \theta + \tan (180^{\circ}+\theta) + \tan (90^{\circ}+\theta) + \tan (360^{\circ}-\theta) \\ \cot \theta + \tan \theta - \cot \theta - \tan \theta = 0 \end{aligned}$$

- What is the value of

$$\frac{\sin^2 30^{\circ}}{\cos^2 45^{\circ}} + \frac{\tan 45^{\circ}}{\sec 60^{\circ}} - \frac{\sin 60^{\circ}}{\cot 45^{\circ}} - \frac{\cos 30^{\circ}}{\sin 90^{\circ}}$$

**Simplify :**

- $\tan (90+A) + (\tan 180+A) \tan (90+A)$
- $\frac{\cos (90+\theta) \cdot \sec (-\theta) \cdot \tan (180-\theta)}{\sec (360+\theta) \cdot \sin (180+\theta) \cdot \cot (90+\theta)}$



Trigonometry - Trigonometrical tables

Use of trigonometrical tables (Ref: Sin, Cos & Tan Table)

Deg.	Minutes from 0 to 4					Mean difference					
	0'	6'	12'	18'	24'	54'	1'	2'	3'	4'	5'
0											
1											
2											
3											
·											
·											
·											
26	..	..	..	x	..	..	..	5			
·											
·											
·											
89											

Sine value for 26°–20'

Refer to Natural sine table.

Degrees column go up to 26° down

Minutes column 18' horizontal and under this note the value which is given as 0.4431.

Under mean difference for 2' in the same horizontal line 5 is given. Add this to the extreme right number noted for 26°–18'.

$$\text{Sine } 26^\circ - 20' = 0.4431 + .0005 = 0.4436$$

Cosine value for 43°–41'

Referring to the Natural cosines table for 43°–36' it is given as 0.7242 and the mean difference for 5' minutes is given as 10.

$$\begin{aligned} \cos 43^\circ - 41' &= \text{value for } \cos 43^\circ .36' \\ &\quad - \text{the value given for} \\ \text{mean difference of } 5' &= 0.7242 - 0.0010 \\ &= 0.7232 \end{aligned}$$

**When reading sine value add the mean difference value. When reading cosine value subtract the mean difference value.**

**Arrangement**

Values of trigonometrical ratios can be taken from mathematical tables.

The left hand vertical column consists of degrees.

The top horizontal column is arranged in minutes in steps of 6' from 0' to 54'. In the extreme right horizontal columns the mean differences are written in minutes from 1' to 5' in steps of 1' to account for angles with minutes between the interval of 6'.

- The values of cosine, cosecant and cotangent decrease when the value of the angle increases.
- For sine, secant and tangent, the value increases when the angle increases.
- The value of sine and cosine will never be more than 1.
- The value of secant and cosecant will never be less than 1.
- The value of Tan and Cot ranges from 0 to ∞.

**EXAMPLE**

From the tables obtain the cosine of 45° 20'.

$$\cos 45^\circ 18' = 0.7108$$

$$\text{mean difference for } 2' = 0.0004$$

$$\cos 45^\circ 20' = 0.7104$$

**SINE TABLE**

1      Sin 25° = 0.4226

2      Sin 17° 5'

$$\begin{array}{r} \sin 17^\circ = 0.2924 \\ \text{Difference } 5' = \quad 14 \\ \hline \sin 17^\circ 5' = 0.2938 \quad \text{Ans} \end{array}$$

3      sin 17° 45' 13"

$$\sin 17^\circ 46' = 0.3051$$

$$\sin 17^\circ 45' = 0.3048$$

$$\text{Difference } 1' = 0.0003$$

$$\begin{aligned}
 1'(\text{or}) 60'' &= 0.0003 \\
 13'' &= \frac{0.0003}{60} \times 13 \\
 &= \frac{0.0039}{60} \\
 &= \frac{0.00039}{6} \\
 &= 0.000065
 \end{aligned}$$

$$\begin{aligned}
 \sin 17^\circ 45' &= 0.3048 \\
 13'' &= 0.000065
 \end{aligned}$$

$$\sin 17^\circ 45' 13'' = 0.304865 \quad \text{Ans.}$$

#### 4 sin 82° 14' 18"

$$\sin 82^\circ 15' = 0.9908$$

$$\sin 82^\circ 14' = 0.9908$$

$$\text{Difference } 1' = 0$$

$$1'(\text{or}) 60'' = 0$$

$$\sin 18'' = 0$$

$$\sin 82^\circ 14' = 0.9908$$

$$18'' = 0.0000$$

$$\sin 82^\circ 41' 18'' = 0.9908 \quad \text{Ans.}$$

Finding the corresponding angles when sine values are given:

#### 1. Sin $\theta = 0.9925$

$$\theta = 83^\circ$$

#### 2. Sin $\theta = 0.8791$

$$0.8788 = \sin 61^\circ 30'$$

$$0.0003 = 2'$$

$$0.8791 = \sin 61^\circ 32'$$

#### 3. sin $\theta = 0.68015$

$$0.6794 = \sin 42^\circ 48'$$

$$0.0006 = 3'$$

$$0.6800 = \sin 42^\circ 51'$$

$$0.6803 = \sin 42^\circ 52'$$

$$\text{Difference } 0.0003 = 1' (\text{or}) 60''$$

$$\begin{aligned}
 0.00015 &= \frac{60}{0.0003} \times 0.00015 \\
 &= \frac{60 \times 15}{30} \\
 &= 30''
 \end{aligned}$$

$$0.6800 = \sin 42^\circ 51'$$

$$0.00015 = 30''$$

$$0.68015 = \sin 42^\circ 51' 30''$$

$$\theta = 42^\circ 51' 30''$$

### Calculations involving tapers

**D** - Big diameter of the taper

**d** - small diameter of the taper

**C** - Taper Ratio - 1:x

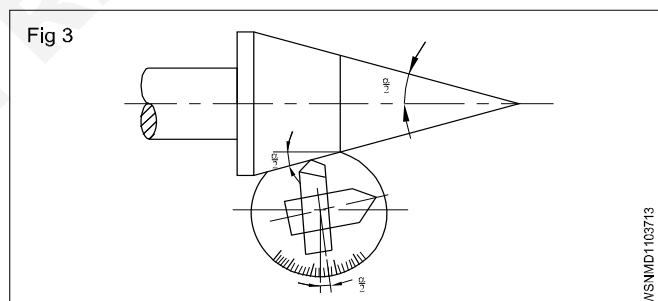
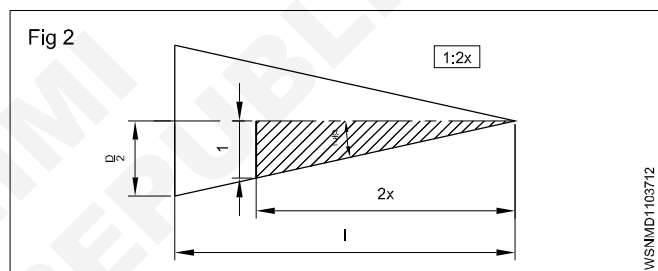
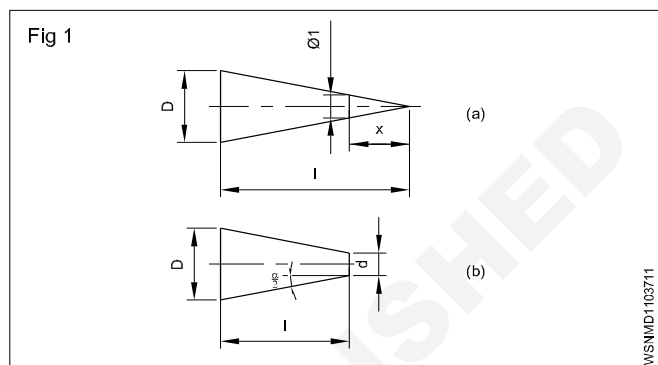

$\frac{C}{2}$  Ratio of inclination - 1:2 x

**l** - length of taper

**a** - included angle of taper

$\frac{\alpha}{2}$  - setting angle

Taper ratio = Ratio of inclination (for wedges).

### Taper ratio

The ratio between the difference in diameter to the length of the taper is known as taper ratio. **D** is the difference in larger diameter shown in the sketch as the small diameter of taper is 0. Taper ratio is  $D : l$ . In the sectioned portion the difference in diameter is 1 and the length of taper is shown as **x**.

$C = D : d = 1 : x$  as per Fig 1 (a),  $C = \frac{D-d}{l}$  as per Fig 1 (b)

### Ratio of inclination

Taking half of the taper,  $\frac{D}{2}$  is the difference in diameter for a taper length of  $l$ , if  $d = 0$ .

$$\therefore \frac{C}{2} = \frac{D}{2l} \quad \text{if the small diameter is 0}$$

$$\text{or } \frac{C}{2} = \frac{D-d}{2l}$$

1 Ratio of inclination =  $\frac{1}{2}$  of the taper ratio.

### Setting angle

One of the methods of turning taper is by swivelling the compound slide to an angle known as setting angle and feeding the tool at an angle to the axis of work.

$$\tan \frac{\alpha}{2} = \frac{C}{2} = \frac{D-d}{2l}$$

$$\tan \frac{\alpha}{2} = \frac{\text{taper ratio}}{2}$$

$$= \frac{\text{difference in diameter}}{2 \times \text{taper length}}$$

NOTE:  $\frac{\alpha}{2}$  is the setting angle which is equal to half of the included angle of the taper.

Taper Ratio  $C = 1 : x$  or  $D : l$  or  $(D-d) : l$

Ratio of inclination  $\frac{C}{2} = 1 : 2x = \frac{D}{2} : l$  or  $\left(\frac{D-d}{2}\right) : l$

Setting angle determination is by the formula

$$\tan \frac{\alpha}{2} = \frac{D-d}{2l} = \frac{C}{2}$$

Fig 4

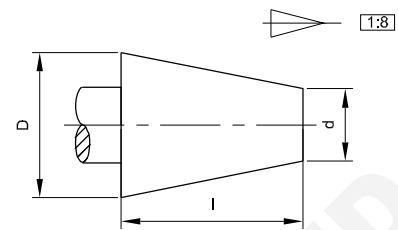

### EXAMPLE

A pivot in the form of a frustum of a cone has a taper ratio 1:8. If the small diameter is 30 mm and length of taper is 80 mm, find its large diameter.

$$C = 1:8 = \frac{1}{8}$$

$$\therefore \frac{D-d}{l} = \frac{1}{8}$$

$$\therefore D-d = \frac{1}{8} \times 80 = 10 \text{ mm.}$$

$$D - 30 \text{ mm} = 10 \text{ mm}$$

$$D = 10 \text{ mm} + 30 \text{ mm} = 40 \text{ mm}$$

$$\text{Large diameter } D = 40 \text{ mm}$$

### Cos Table

#### 1 Cos 38°

$$\text{Cos } 38^\circ = 0.7880$$

#### 2 Cos 83°12'

$$\text{Cos } 83^\circ 12' = 0.1184$$

#### 3 Cos 26°40'

$$\text{Cos } 26^\circ 36' = 0.8942$$

$$4' = 5(-)$$

---

$$\text{Cos } 26^\circ 40' = 0.8937$$

---

#### 4 Cos 31°20'

$$\text{Cos } 31^\circ 18' = 0.8545$$

$$2' = 3(-)$$

---

$$\text{Cos } 31^\circ 20' = 0.8542$$

---

Find the corresponding angles when cos values are given:

$$1 \text{ Cos } \theta = 0.5150$$

$$\theta = 59^\circ$$

$$2 \text{ Cos } \theta = 0.0192$$

$$\theta = 88^\circ 54'$$

$$3 \text{ Cos } \theta = 0.9682$$

$$0.9686 = \text{cos } 14^\circ 24'$$

$$(-) \quad 4 = 5'$$

---

$$0.9682 = \text{cos } 14^\circ 29'$$

---

$$\theta = 14^\circ 29'$$

4 **Cos θ = 0.8476**

0.8480 = cos 32° 0'  
 (-) 0.0003 = 2'

0.8477 = cos 32° 2'  
 0.8475 = cos 32° 3'

0.0002 = 1' (or) 60"  
 60  
 0.0001 = ----- x 0.0001  
 0.0002  
 60  
 = ----- x 1  
 2  
 = 30"  
 0.8477 = Cos 32° 2'

(-) 0.0001 = 30" (+)

**0.8476 = Cos 32° 2' 30"**

**tan Table**

**1 tan 35° 37'**

tan 35° 36' = 0.7159  
 1' = 0.0004

tan 35° 37' = 0.7163

**2 tan 50° 5'**

Tan 50° 0' = 1.1918  
 5' = 0.0036

Tan 50° 5' = 1.1954

**Find the corresponding angles when tan values are given**

1 tan θ = 0.3972  
 0.3959 = tan 21° 36'  
 0.0013 = 4'

0.3972 = tan 21° 40'

2 tan θ = 1.0065  
 1.0035 = tan 45° 6'  
 0.0030 = 5'

1.0065 = tan 45° 11'

**Problems Related with Trigonometrical tables**

**1 A 250 mm Sine bar is used to measure an angle. If the difference in height is 5 cm, find the angle.**

$Sin\theta = \frac{Opp.side}{Hyp.} = \frac{h}{l}$

$= \frac{5\text{ cm}}{250\text{ mm}}$

$= \frac{50\text{ mm}}{250\text{ mm}}$

$= 0.2000$

$\theta = 11^\circ 32'$

**2 Find the height of the slip gauge if a Sine bar with plugs of 10" centre is set up to inspect a taper having an included angle of 9° 56".**

$Sin\theta = \frac{Opp.side}{Hyp.} = \frac{h}{l}$

$Sin\ 9^\circ 56'' = \frac{h}{10}$

$\therefore h = 10 \times sin\ 9^\circ 56''$

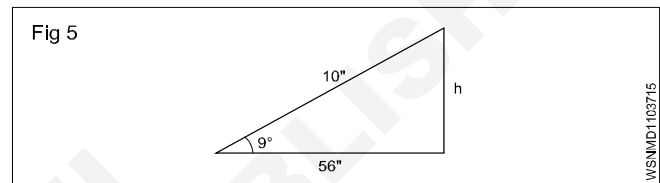

$Sin\ 9^\circ 0'' = 0.1564$

$Sin\ 9^\circ 1'' = 0.1567$

$1' (or) 60'' = 0.0003$

$56'' = \frac{0.0003}{60} \times 56$

$= \frac{0.0168}{60}$

$= \frac{0.00168}{6}$

$= 0.00028$

$sin\ 9^\circ 0' 00'' = 0.1564$

$56'' = 0.00028$

$sin\ 9^\circ 0' 56'' = 0.15668$

$h = 10 \times sin\ 9^\circ 56''$

$= 10 \times 0.15668$

$= 1.5668\text{ cm}$

**Height of slip gauge = 1.5668"**

**3 Find the angle which the ladder makes with the ground if the foot of a 4.5 m long ladder is placed at 1 m away from the wall.**

In Right angled D

$Cos\ C = \frac{BC}{AC}$

$$\cos \theta = \frac{1 \text{ m}}{4.5 \text{ m}} = 0.2222$$

$$\cos = 0.2222$$

$$0.2233 = \cos 77^\circ 6'$$

$$(-) 0.0011 = 4' (+)$$

$$0.2222 = \cos 77^\circ 10'$$

$$\theta = 77^\circ 10'$$

Fig 6

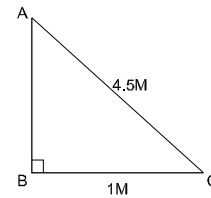

WSSNMD1103716

## Assignment

### I Find the values of the given angles

- 1  $\sin 65^\circ$
- 2  $\sin 42^\circ 23'$
- 3  $\sin 66^\circ 35' 32''$
- 4  $\sin 7^\circ 15' 41''$
- 5  $\sin 27^\circ 27''$
- 6  $\cos 26^\circ 40'$
- 7  $\cos 47^\circ 39'$
- 8  $\cos 79^\circ 31' 53''$
- 9  $\tan 28^\circ 45'$
- 10  $\tan 67^\circ 27' 36''$

### II Find corresponding angles for given values

- 1  $\sin \theta = 0.3062$
- 2  $\sin \theta = 0.6002$
- 3  $\sin \theta = 0.22453$
- 4  $\sin \theta = 0.04802$
- 5  $\cos \theta = 0.6446$

$$6 \cos \theta = 0.8926$$

$$7 \cos \theta = 0.11773$$

$$8 \cos \theta = 0.21646$$

$$9 \tan \theta = 0.3411$$

$$10 \tan \theta = 2.3868$$

### III

- 1 Calculate its base, if the slant height of a cone is 12.25 cm and the vertex angle is  $110^\circ$ .
- 2 A ladder 2.5 m long makes an angle of  $60^\circ$  with the ground. Find the height of the wall where the ladder touches the wall.
- 3 A sine bar of 200 mm is to be set at an angle of  $15^\circ 15' 3''$ . Select the slip gauge block to built up the required height.
- 4 In a right angled triangle ABC,  $\angle C = 90^\circ$ , If AB = 50 mm and  $\angle B = 75^\circ$ , Find the remaining sides.
- 5 Calculate the required length of the bar for this point if a centre point having an included angle of  $60^\circ$  is to be turned at the end of a 50 mm dia bar.

## Natural Sines

°	0°	6'	12'	18'	24'	30'	36'	42'	48'	54'	1'	2'	3'	4'	5'
	0.0°	0.1°	0.2°	0.3°	0.4°	0.5°	0.6°	0.7°	0.8°	0.9°					
0	0.0000	0.0017	0.0035	0.0052	0.0070	0.0087	0.0105	0.0122	0.0140	0.0157	3	6	9	12	15
1	0.0175	0.0192	0.0209	0.0227	0.0244	0.0262	0.0279	0.0297	0.0314	0.0332	3	6	9	12	15
2	0.0349	0.0366	0.0384	0.0401	0.0419	0.0436	0.0454	0.0471	0.0488	0.0506	3	6	9	12	15
3	0.0523	0.0541	0.0558	0.0576	0.0593	0.0610	0.0628	0.0645	0.0663	0.0680	3	6	9	12	15
4	0.0698	0.0715	0.0732	0.0750	0.0767	0.0785	0.0802	0.0819	0.0837	0.0854	3	6	9	12	14
5	0.0872	0.0899	0.0906	0.0924	0.0941	0.0958	0.0976	0.0993	0.1011	0.1028	3	6	9	12	14
6	0.1045	0.1063	0.1080	0.1097	0.1115	0.1132	0.1149	0.1167	0.1184	0.1201	3	6	9	12	14
7	0.1219	0.1236	0.1253	0.1271	0.1288	0.1305	0.1323	0.1340	0.1357	0.1374	3	6	9	12	14
8	0.1392	0.1409	0.1426	0.1444	0.1461	0.1478	0.1495	0.1513	0.1530	0.1547	3	6	9	11	14
9	0.1564	0.1582	0.1599	0.1616	0.1633	0.1650	0.1668	0.1685	0.1702	0.1719	3	6	9	11	14
10	0.1736	0.1754	0.1771	0.1788	0.1805	0.1822	0.1840	0.1857	0.1874	0.1891	3	6	9	11	14
11	0.1908	0.1925	0.1942	0.1959	0.1977	0.1994	0.2011	0.2028	0.2045	0.2062	3	6	9	12	14
12	0.2079	0.2096	0.2113	0.2130	0.2147	0.2164	0.2181	0.2198	0.2215	0.2232	3	6	9	11	14
13	0.2250	0.2267	0.2284	0.2300	0.2317	0.2334	0.2351	0.2368	0.2385	0.2402	3	6	8	11	14
14	0.2419	0.2436	0.2453	0.2470	0.2487	0.2504	0.2521	0.2538	0.2554	0.2571	3	6	8	11	14
15	0.2558	0.2605	0.2622	0.2639	0.2656	0.2672	0.2689	0.2706	0.2723	0.2740	3	6	8	11	14
16	0.2756	0.2773	0.2790	0.2807	0.2823	0.2840	0.2857	0.2874	0.2890	0.2907	3	6	8	11	14
17	0.2924	0.2940	0.2957	0.2974	0.2990	0.3007	0.3024	0.3040	0.3057	0.3074	3	6	8	11	14
18	0.3090	0.3107	0.3123	0.3140	0.3156	0.3173	0.3190	0.3206	0.3223	0.3239	3	6	8	11	14
19	0.3256	0.3272	0.3289	0.3305	0.3322	0.3338	0.3355	0.3371	0.3387	0.3404	3	5	8	11	14
20	0.3420	0.3437	0.3453	0.3469	0.3486	0.3502	0.3518	0.3535	0.3551	0.3567	3	5	8	11	14
21	0.3584	0.3600	0.3616	0.3633	0.3649	0.3665	0.3681	0.3697	0.3714	0.3730	3	5	8	11	14
22	0.3746	0.3762	0.3778	0.3795	0.3811	0.3827	0.3843	0.3859	0.3875	0.3891	3	5	8	11	13
23	0.3907	0.3923	0.3939	0.3955	0.3971	0.3987	0.4003	0.4019	0.4035	0.4051	3	5	8	11	13
24	0.4067	0.4083	0.4099	0.4115	0.4131	0.4147	0.4163	0.4179	0.4195	0.4210	3	5	8	11	13
25	0.4226	0.4242	0.4258	0.4274	0.4289	0.4305	0.4321	0.4337	0.4352	0.4368	3	5	8	11	13
26	0.4384	0.4399	0.4415	0.4431	0.4446	0.4462	0.4478	0.4493	0.4509	0.4524	3	5	8	10	13
27	0.4540	0.4555	0.4571	0.4586	0.4602	0.4617	0.4633	0.4648	0.4664	0.4679	3	5	8	10	13
28	0.4695	0.4710	0.4726	0.4741	0.4756	0.4772	0.4787	0.4802	0.4818	0.4833	3	5	8	10	13
29	0.4848	0.4863	0.4879	0.4894	0.4909	0.4924	0.4939	0.4955	0.4970	0.4985	3	5	8	10	13
30	0.500	0.5015	0.5030	0.5045	0.5060	0.5075	0.5090	0.5105	0.5120	0.5135	3	5	8	10	13
31	0.5150	0.5165	0.5180	0.5195	0.5210	0.5225	0.5240	0.5255	0.5270	0.5284	2	5	7	10	12
32	0.5299	0.5314	0.5329	0.5344	0.5358	0.5373	0.5388	0.5402	0.5417	0.5432	2	5	7	10	12
33	0.5446	0.5461	0.5476	0.5490	0.5505	0.5519	0.5534	0.5548	0.5563	0.5577	2	5	7	10	12
34	0.5592	0.5606	0.5621	0.5635	0.5650	0.5664	0.5678	0.5693	0.5707	0.5721	2	5	7	10	12
35	0.5736	0.5750	0.5764	0.5779	0.5793	0.5807	0.5821	0.5835	0.5850	0.5864	2	5	7	9	12
36	0.5878	0.5892	0.5906	0.5920	0.5934	0.5948	0.5962	0.5976	0.5990	0.6004	2	5	7	9	12
37	0.6018	0.6032	0.6046	0.6060	0.6074	0.6088	0.6101	0.6115	0.6129	0.6143	2	5	7	9	12
38	0.6157	0.6170	0.6184	0.6198	0.6211	0.6225	0.6239	0.6252	0.6266	0.6280	2	5	7	9	11
39	0.6293	0.6307	0.6320	0.6334	0.6347	0.6361	0.6374	0.6388	0.6401	0.6414	2	4	7	9	11
40	0.6428	0.6441	0.6455	0.6468	0.6481	0.6494	0.6508	0.6521	0.6534	0.6547	2	4	7	9	11
41	0.6561	0.6574	0.6587	0.6600	0.6613	0.6626	0.6639	0.6652	0.6665	0.6678	2	4	7	9	11
42	0.6691	0.6704	0.6717	0.6730	0.6743	0.6756	0.6769	0.6782	0.6794	0.6807	2	4	6	9	11
43	0.6820	0.6833	0.6845	0.6858	0.6871	0.6884	0.6896	0.6909	0.6921	0.6934	2	4	6	8	11
44	0.6947	0.6959	0.6972	0.6984	0.6997	0.7009	0.7022	0.7034	0.7046	0.7059	2	4	6	8	10
45	0.7071	0.7083	0.7096	0.7108	0.7120	0.7133	0.7145	0.7157	0.7169	0.7181	2	4	6	8	10
46	0.7193	0.7206	0.7218	0.7230	0.7242	0.7254	0.7266	0.7278	0.7290	0.7302	2	4	6	8	10
47	0.7314	0.7325	0.7337	0.7349	0.7361	0.7373	0.7385	0.7396	0.7408	0.7420	2	4	6	8	10
48	0.7431	0.7443	0.7455	0.7466	0.7478	0.7490	0.7501	0.7513	0.7524	0.7536	2	4	6	8	10
49	0.7547	0.7558	0.7570	0.7581	0.7593	0.7604	0.7615	0.7627	0.7638	0.7649	2	4	6	8	9
50	0.7660	0.7672	0.7683	0.7694	0.7705	0.7716	0.7727	0.7738	0.7749	0.7760	2	4	6	7	9
51	0.7771	0.7782	0.7793	0.7804	0.7815	0.7826	0.7837	0.7848	0.7859	0.7869	2	4	5	7	9
52	0.7880	0.7891	0.7902	0.7912	0.7923	0.7934	0.7944	0.7955	0.7965	0.7976	2	4	5	7	9
53	0.7986	0.7997	0.8007	0.8018	0.8028	0.8039	0.8049	0.8059	0.8070	0.8080	2	3	5	7	9
54	0.8090	0.8100	0.8111	0.8121	0.8131	0.8141	0.8151	0.8161	0.8171	0.8181	2	3	5	7	8
55	0.8192	0.8202	0.8211	0.8221	0.8231	0.8241	0.8251	0.8261	0.8271	0.8281	2	3	5	7	8
56	0.8290	0.8300	0.8310	0.8320	0.8329	0.8339	0.8348	0.8358	0.8368	0.8377	2	3	5	6	8
57	0.8387	0.8396	0.8406	0.8415	0.8425	0.8434	0.8443	0.8453	0.8462	0.8471	2	3	5	6	8
58	0.8480	0.8490	0.8499	0.8508	0.8517	0.8526	0.8536	0.8545	0.8554	0.8563	2	3	5	6	8
59	0.8572	0.8581	0.8590	0.8599	0.8607	0.8616	0.8625	0.8634	0.8643	0.8652	1	3	4	6	7

### Natural Sines

°	0' 0.0°	6' 0.1°	12' 0.2°	18' 0.3°	24' 0.4°	30' 0.5°	36' 0.6°	42' 0.7°	48' 0.8°	54' 0.9°	1'	2'	3'	4'	5'
60	0.8660	0.8669	0.8678	0.8686	0.8695	0.8704	0.8712	0.8721	0.8729	0.8738	1	3	4	6	7
61	0.8746	0.8755	0.8763	0.8771	0.8780	0.8788	0.8796	0.8805	0.8813	0.8821	1	3	4	6	7
62	0.8829	0.8838	0.8846	0.8854	0.8862	0.8870	0.8878	0.8886	0.8894	0.8902	1	3	4	5	7
63	0.8910	0.8918	0.8926	0.8934	0.8942	0.8949	0.8957	0.8965	0.8973	0.8980	1	3	4	5	6
64	0.8988	0.8996	0.9003	0.9011	0.9018	0.9026	0.9033	0.9041	0.9048	0.9056	1	3	4	5	6
65	0.9063	0.9070	0.9078	0.9085	0.9092	0.9100	0.9107	0.9114	0.9121	0.9128	1	2	4	5	6
66	0.9135	0.9143	0.9150	0.9157	0.9164	0.9171	0.9178	0.9184	0.9191	0.9198	1	2	3	5	6
67	0.9205	0.9212	0.9219	0.9225	0.9232	0.9239	0.9245	0.9252	0.9259	0.9265	1	2	3	4	6
68	0.9272	0.9278	0.9285	0.9291	0.9298	0.9304	0.9311	0.9317	0.9323	0.9330	1	2	3	4	5
69	0.9336	0.9342	0.9348	0.9354	0.9361	0.9367	0.9373	0.9379	0.9385	0.9391	1	2	3	4	5
70	0.9397	0.9403	0.9409	0.9415	0.9421	0.9426	0.9432	0.9438	0.9444	0.9449	1	2	3	4	5
71	0.9455	0.9461	0.9466	0.9472	0.9478	0.9483	0.9489	0.9494	0.9500	0.9505	1	2	3	4	5
72	0.9511	0.9516	0.9521	0.9527	0.9532	0.9537	0.9542	0.9548	0.9553	0.9558	1	2	3	3	4
73	0.9563	0.9568	0.9573	0.9578	0.9583	0.9588	0.9593	0.9598	0.9603	0.9608	1	2	2	3	4
74	0.9613	0.9617	0.9622	0.9627	0.9632	0.9636	0.9641	0.9646	0.9650	0.9655	1	2	2	3	4
75	0.9659	0.9664	0.9668	0.9673	0.9677	0.9681	0.9686	0.9690	0.9694	0.9699	1	1	2	3	4
76	0.9703	0.9707	0.9711	0.9715	0.9720	0.9724	0.9728	0.9732	0.9736	0.9740	1	1	2	3	3
77	0.9744	0.9748	0.9751	0.9755	0.9759	0.9763	0.9767	0.9770	0.9774	0.9778	1	1	2	2	3
78	0.9781	0.9785	0.9789	0.9792	0.9796	0.9799	0.9803	0.9806	0.9810	0.9813	1	1	2	2	3
79	0.9816	0.9820	0.9823	0.9826	0.9829	0.9833	0.9836	0.9839	0.9842	0.9845	1	1	2	2	3
80	0.9848	0.9851	0.9854	0.9857	0.9860	0.9863	0.9866	0.9869	0.9871	0.9874	0	1	1	2	2
81	0.9877	0.9880	0.9882	0.9885	0.9888	0.9890	0.9893	0.9895	0.9898	0.9900	0	1	1	2	2
82	0.9903	0.9905	0.9907	0.9910	0.9912	0.9914	0.9917	0.9919	0.9921	0.9923	0	1	1	1	2
83	0.9925	0.9928	0.9930	0.9932	0.9934	0.9936	0.9938	0.9940	0.9942	0.9943	0	1	1	1	2
84	0.9945	0.9947	0.9949	0.9951	0.9952	0.9954	0.9956	0.9957	0.9959	0.9960	0	1	1	1	1
85	0.9962	0.9963	0.9965	0.9966	0.9968	0.9969	0.9971	0.9972	0.9973	0.9974	0	0	1	1	1
86	0.9976	0.9977	0.9978	0.9979	0.9980	0.9981	0.9982	0.9983	0.9984	0.9985	0	0	1	1	1
87	0.9986	0.9987	0.9988	0.9989	0.9990	0.9990	0.9991	0.9992	0.9993	0.9993	0	0	0	1	1
88	0.9994	0.9995	0.9995	0.9996	0.9996	0.9997	0.9997	0.9997	0.9998	0.9998	0	0	0	0	0
89	0.9998	0.9999	0.9999	0.9999	0.9999	1.0000	1.0000	1.0000	1.0000	1.0000	0	0	0	0	0
90	1.0000														

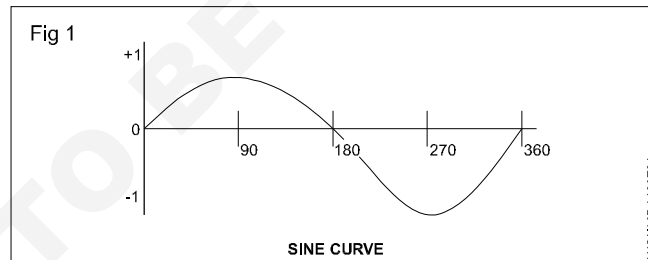

Quadrant	Angle	sinA =	Examples
First	0 to 90°	sin A	sin 34°38' = 0.5683
Second	90° to 180°	sin(180° – A)	sin 145°22' = sin(180° – 145° 22') = sin 34°38' = 0.5683
Third	180° to 270°	–sin(A – 180°)	sin 214°38' = –sin(214°38' – 180°) = –sin34°38' = –0.5683
Fourth	270° to 360°	–sin(360° – A)	sin 325°22' = –sin(360° – 325°22') = – sin 34°38' = –0.5683

**Natural Cosines**

**Numbers in different columns to be subtracted, not added**

°	0' 0.0°	6' 0.1°	12' 0.2°	18' 0.3°	24' 0.4°	30' 0.5°	36' 0.6°	42' 0.7°	48' 0.8°	54' 0.9°	1'	2'	3'	4'	5'
0	1.0000	1.0000	1.0000	1.0000	1.0000	1.0000	0.9999	0.9999	0.9999	0.9999	0	0	0	0	0
1	0.9998	0.9998	0.9998	0.9997	0.9997	0.9997	0.9996	0.9996	0.9995	0.9995	0	0	0	0	0
2	0.9994	0.9993	0.9993	0.9992	0.9991	0.9990	0.9990	0.9989	0.9988	0.9987	0	0	0	1	1
3	0.9986	0.9985	0.9984	0.9983	0.9982	0.9981	0.9980	0.9979	0.9978	0.9977	0	0	1	1	1
4	0.9976	0.9974	0.9973	0.9972	0.9971	0.9969	0.9968	0.9966	0.9965	0.9963	0	0	1	1	1
5	0.9962	0.9960	0.9959	0.9957	0.9956	0.9954	0.9952	0.9951	0.9949	0.9947	0	1	1	1	1
6	0.9945	0.9943	0.9942	0.9940	0.9938	0.9936	0.9934	0.9932	0.9930	0.9928	0	1	1	1	2
7	0.9925	0.9923	0.9921	0.9919	0.9917	0.9914	0.9912	0.9910	0.9907	0.9905	0	1	1	1	2
8	0.9903	0.9900	0.9898	0.9895	0.9893	0.9890	0.9888	0.9885	0.9882	0.9880	0	1	1	2	2
9	0.9877	0.9874	0.9871	0.9869	0.9866	0.9863	0.9860	0.9857	0.9854	0.9851	0	1	1	2	2
10	0.9848	0.9845	0.9842	0.9839	0.9836	0.9833	0.9829	0.9826	0.9823	0.9820	1	1	2	2	3
11	0.9816	0.9813	0.9810	0.9806	0.9803	0.9799	0.9796	0.9792	0.9789	0.9785	1	1	2	2	3
12	0.9781	0.9778	0.9774	0.9770	0.9767	0.9763	0.9759	0.9755	0.9751	0.9748	1	1	2	2	3
13	0.9744	0.9740	0.9736	0.9732	0.9728	0.9724	0.9720	0.9715	0.9711	0.9707	1	1	2	3	3
14	0.9703	0.9699	0.9694	0.9690	0.9686	0.9681	0.9677	0.9673	0.9668	0.9664	1	1	2	3	4
15	0.9659	0.9655	0.9650	0.9646	0.9641	0.9636	0.9632	0.9627	0.9622	0.9617	1	2	2	3	4
16	0.9613	0.9608	0.9603	0.9598	0.9593	0.9588	0.9583	0.9578	0.9573	0.9568	1	2	2	3	4
17	0.9563	0.9558	0.9553	0.9548	0.9542	0.9537	0.9532	0.9527	0.9521	0.9516	1	2	3	3	4
18	0.9511	0.9505	0.9500	0.9494	0.9489	0.9483	0.9478	0.9472	0.9466	0.9461	1	2	3	4	5
19	0.9455	0.9449	0.9444	0.9438	0.9432	0.9426	0.9421	0.9415	0.9409	0.9403	1	2	3	4	5
20	0.9397	0.9391	0.9385	0.9379	0.9373	0.9367	0.9361	0.9354	0.9348	0.9342	1	2	3	4	5
21	0.9336	0.9330	0.9323	0.9317	0.9311	0.9304	0.9298	0.9291	0.9285	0.9278	1	2	3	4	5
22	0.9272	0.9265	0.9259	0.9252	0.9245	0.9239	0.9232	0.9225	0.9219	0.9212	1	2	3	4	6
23	0.9205	0.9198	0.9191	0.9184	0.9178	0.9171	0.9164	0.9157	0.9150	0.9143	1	2	3	5	6
24	0.9135	0.9128	0.9121	0.9114	0.9107	0.9100	0.9092	0.9085	0.9078	0.9070	1	2	4	5	6
25	0.9063	0.9056	0.9048	0.9041	0.9033	0.9026	0.9018	0.9011	0.9003	0.8996	1	3	4	5	6
26	0.8988	0.8980	0.8973	0.8965	0.8957	0.8949	0.8942	0.8934	0.8926	0.8918	1	3	4	5	6
27	0.8910	0.8902	0.8894	0.8886	0.8878	0.8870	0.8862	0.8854	0.8846	0.8838	1	3	4	5	7
28	0.8829	0.8821	0.8813	0.8805	0.8796	0.8788	0.8780	0.8771	0.8763	0.8755	1	3	4	6	7
29	0.8746	0.8738	0.8729	0.8721	0.8712	0.8704	0.8695	0.8686	0.8678	0.8669	1	3	4	6	7
30	0.8660	0.8652	0.8643	0.8634	0.8625	0.8616	0.8607	0.8599	0.8590	0.8581	1	3	4	6	7
31	0.8572	0.8563	0.8554	0.8545	0.8536	0.8526	0.8517	0.8508	0.8499	0.8490	2	3	5	6	8
32	0.8480	0.8471	0.8462	0.8453	0.8443	0.8434	0.8425	0.8415	0.8406	0.8396	2	3	5	6	8
33	0.8387	0.8377	0.8368	0.8358	0.8348	0.8339	0.8329	0.8320	0.8310	0.8300	2	3	5	6	8
34	0.8290	0.8281	0.8271	0.8261	0.8251	0.8241	0.8231	0.8221	0.8211	0.8202	2	3	5	7	8
35	0.8192	0.8181	0.8171	0.8161	0.8151	0.8141	0.8131	0.8121	0.8111	0.8100	2	3	5	7	8
36	0.8090	0.8080	0.8070	0.8059	0.8049	0.8039	0.8028	0.8018	0.8007	0.7997	2	3	5	7	9
37	0.7986	0.7976	0.7965	0.7955	0.7944	0.7934	0.7923	0.7912	0.7902	0.7891	2	4	5	7	9
38	0.7880	0.7869	0.7859	0.7848	0.7837	0.7826	0.7815	0.7804	0.7793	0.7782	2	4	5	7	9
39	0.7771	0.7760	0.7749	0.7738	0.7727	0.7716	0.7705	0.7694	0.7683	0.7672	2	4	6	7	9
40	0.7660	0.7649	0.7638	0.7627	0.7615	0.7604	0.7593	0.7581	0.7570	0.7559	2	4	6	8	9
41	0.7547	0.7536	0.7524	0.7513	0.7501	0.7490	0.7478	0.7466	0.7455	0.7443	2	4	6	8	10
42	0.7431	0.7420	0.7408	0.7396	0.7385	0.7373	0.7361	0.7349	0.7337	0.7325	2	4	6	8	10
43	0.7314	0.7302	0.7290	0.7278	0.7266	0.7254	0.7242	0.7230	0.7218	0.7206	2	4	6	8	10
44	0.7193	0.7181	0.7169	0.7157	0.7145	0.7133	0.7120	0.7108	0.7096	0.7083	2	4	6	8	10
45	0.7071	0.7059	0.7046	0.7034	0.7022	0.7009	0.6997	0.6984	0.6972	0.6959	2	4	6	8	10
46	0.6947	0.6934	0.6921	0.6909	0.6896	0.6884	0.6871	0.6858	0.6845	0.6833	2	4	6	8	11
47	0.6820	0.6807	0.6794	0.6782	0.6769	0.6756	0.6743	0.6730	0.6717	0.6704	2	4	6	9	11
48	0.6691	0.6678	0.6665	0.6652	0.6639	0.6626	0.6613	0.6600	0.6587	0.6574	2	4	7	9	11
49	0.6561	0.6547	0.6534	0.6521	0.6508	0.6494	0.6481	0.6468	0.6455	0.6441	2	4	7	9	11
50	0.6428	0.6414	0.6401	0.6388	0.6374	0.6361	0.6347	0.6334	0.6320	0.6307	2	4	7	9	11
51	0.6293	0.6280	0.6266	0.6252	0.6239	0.6225	0.6211	0.6198	0.6184	0.6170	2	5	7	9	11
52	0.6157	0.6143	0.6129	0.6115	0.6101	0.6088	0.6074	0.6060	0.6046	0.6032	2	5	7	9	12
53	0.6018	0.6004	0.5990	0.5976	0.5962	0.5948	0.5934	0.5920	0.5906	0.5892	2	5	7	9	12
54	0.5878	0.5864	0.5850	0.5835	0.5821	0.5807	0.5793	0.5779	0.5764	0.5750	2	5	7	9	12
55	0.5736	0.5721	0.5707	0.5693	0.5678	0.5664	0.5650	0.5635	0.5621	0.5606	2	5	7	10	12
56	0.5592	0.5577	0.5563	0.5548	0.5534	0.5519	0.5505	0.5490	0.5476	0.5461	2	5	7	10	12
57	0.5446	0.5432	0.5417	0.5402	0.5388	0.5373	0.5358	0.5344	0.5329	0.5314	2	5	7	10	12
58	0.5299	0.5284	0.5270	0.5255	0.5240	0.5225	0.5210	0.5195	0.5180	0.5165	2	5	7	10	12
59	0.5150	0.5135	0.5120	0.5105	0.5090	0.5075	0.5060	0.5045	0.5030	0.5015	3	5	8	10	13



## Natural Cosines

Numbers in different columns to be subtracted, not added

°	0'	6'	12'	18'	24'	30'	36'	42'	48'	54'	1'	2'	3'	4'	5'
	0.0°	0.1°	0.2°	0.3°	0.4°	0.5°	0.6°	0.7°	0.8°	0.9°					
60	0.5000	0.4985	0.4970	0.4955	0.4939	0.4924	0.4909	0.4894	0.4879	0.4863	3	5	8	10	13
61	0.4848	0.4833	0.4818	0.4802	0.4787	0.4772	0.4756	0.4741	0.4726	0.4710	3	5	8	10	13
62	0.4695	0.4679	0.4664	0.4648	0.4633	0.4617	0.4602	0.4586	0.4571	0.4555	3	5	8	10	13
63	0.4540	0.4524	0.4509	0.4493	0.4478	0.4462	0.4446	0.4431	0.4415	0.4399	3	5	8	10	13
64	0.4384	0.4368	0.4352	0.4337	0.4321	0.4305	0.4289	0.4274	0.4258	0.4242	3	5	8	11	13
65	0.4226	0.4210	0.4195	0.4179	0.4163	0.4147	0.4131	0.4115	0.4099	0.4083	3	5	8	11	13
66	0.4067	0.4051	0.4035	0.4019	0.4003	0.3987	0.3971	0.3955	0.3939	0.3923	3	5	8	11	13
67	0.3907	0.3891	0.3875	0.3859	0.3843	0.3827	0.3811	0.3795	0.3778	0.3762	3	5	8	11	13
68	0.3746	0.3730	0.3714	0.3697	0.3681	0.3665	0.3649	0.3633	0.3616	0.3600	3	5	8	11	14
69	0.3584	0.3567	0.3551	0.3535	0.3518	0.3502	0.3486	0.3469	0.3453	0.3437	3	5	8	11	14
70	0.3420	0.3404	0.3387	0.3371	0.3355	0.3338	0.3322	0.3305	0.3289	0.3272	3	5	8	11	14
71	0.3256	0.3239	0.3223	0.3206	0.3190	0.3173	0.3156	0.3140	0.3123	0.3107	3	6	8	11	14
72	0.3090	0.3074	0.3057	0.3040	0.3024	0.3007	0.2990	0.2974	0.2957	0.2940	3	6	8	11	14
73	0.2924	0.2907	0.2890	0.2874	0.2857	0.2840	0.2823	0.2807	0.2790	0.2773	3	6	8	11	14
74	0.2756	0.2740	0.2723	0.2706	0.2689	0.2672	0.2656	0.2639	0.2622	0.2605	3	6	8	11	14
75	0.2588	0.2571	0.2554	0.2538	0.2521	0.2504	0.2487	0.2470	0.2453	0.2436	3	6	8	11	14
76	0.2419	0.2402	0.2385	0.2368	0.2351	0.2334	0.2317	0.2300	0.2284	0.2267	3	6	8	11	14
77	0.2250	0.2233	0.2215	0.2198	0.2181	0.2164	0.2147	0.2130	0.2113	0.2096	3	6	9	11	14
78	0.2079	0.2062	0.2045	0.2028	0.2011	0.1994	0.1977	0.1959	0.1942	0.1925	3	6	9	11	14
79	0.1908	0.1891	0.1874	0.1857	0.1840	0.1822	0.1805	0.1788	0.1771	0.1754	3	6	9	11	14
80	0.1736	0.1719	0.1702	0.1685	0.1668	0.1650	0.1633	0.1616	0.1599	0.1582	3	6	9	11	14
81	0.1564	0.1547	0.1530	0.1513	0.1495	0.1478	0.1461	0.1444	0.1426	0.1409	3	6	9	11	14
82	0.1392	0.1374	0.1357	0.1340	0.1323	0.1305	0.1288	0.1271	0.1253	0.1236	3	6	9	12	14
83	0.1219	0.1201	0.1184	0.1167	0.1149	0.1132	0.1115	0.1097	0.1080	0.1063	3	6	9	12	14
84	0.1045	0.1028	0.1011	0.0993	0.0976	0.0958	0.0941	0.0924	0.0906	0.0889	3	6	9	12	14
85	0.0872	0.0854	0.0837	0.0819	0.0802	0.0785	0.0767	0.0750	0.0732	0.0715	3	6	9	12	14
86	0.0698	0.0680	0.0663	0.0645	0.0628	0.0610	0.0593	0.0576	0.0558	0.0541	3	6	9	12	15
87	0.0523	0.0506	0.0488	0.0471	0.0454	0.0436	0.0419	0.0401	0.0384	0.0366	3	6	9	12	15
88	0.0349	0.0332	0.0314	0.0297	0.0279	0.0262	0.0244	0.0227	0.0209	0.0192	3	6	9	12	15
89	0.0175	0.0157	0.0140	0.0122	0.0105	0.0087	0.0070	0.0052	0.0035	0.0017	3	6	9	12	15
90	0.0000														

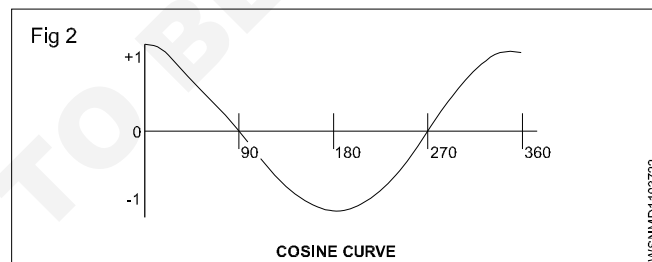

Quadrant	Angle	cos A =	Examples
First	0 to 90°	cos A	cos 33°26' = 0.8345
Second	90° to 180°	-cos(180° - A)	sin 146°34' = -cos(180° - 146°34') = -cos 33°26' = -0.8345
Third	180° to 270°	cos(A - 180°)	cos 213°26' = -cos(213°26' - 180°) = -cos 33°26' = -0.8345
Fourth	270° to 360°	cos(360° - A)	cos 326°34' = cos(360° - 326°34') = cos 33°26' = 0.8345



## Natural Tangents

°	0'	6'	12'	18'	24'	30'	36'	42'	48'	54'	1'	2'	3'	4'	5'
	0.0°	0.1°	0.2°	0.3°	0.4°	0.5°	0.6°	0.7°	0.8°	0.9°					
60	1.7321	1.7391	1.7461	1.7532	1.7603	1.7675	1.7747	1.7820	1.7893	1.7966	12	24	36	48	60
61	1.8040	1.8115	1.8190	1.8265	1.8341	1.8418	1.8495	1.8572	1.8650	1.8728	13	26	38	51	64
62	1.8807	1.8887	1.8967	1.9047	1.9128	1.9210	1.9292	1.9375	1.9458	1.9542	14	27	41	55	68
63	1.9626	1.9711	1.9797	1.9883	1.9970	2.0057	2.0145	2.0233	2.0323	2.0413	15	29	44	58	73
64	2.0503	2.0594	2.0686	2.0778	2.0872	2.0965	2.1060	2.1155	2.1251	2.1348	16	31	47	63	78
65	2.1445	2.1543	2.1642	2.1742	2.1842	2.1943	2.2045	2.2148	2.2251	2.2355	17	34	51	68	85
66	2.2460	2.2566	2.2673	2.2781	2.2889	2.2998	2.3109	2.3220	2.3332	2.3445	18	37	55	73	92
67	2.3559	2.3673	2.3789	2.3906	2.4023	2.4142	2.4262	2.4383	2.4504	2.4627	20	40	60	79	99
68	2.4751	2.4876	2.5002	2.5129	2.5257	2.5386	2.5517	2.5649	2.5782	2.5916	22	43	65	87	108
69	2.6051	2.6187	2.6325	2.6464	2.6605	2.6746	2.6889	2.7034	2.7179	2.7326	24	47	71	95	119
70	2.7475	2.7625	2.7776	2.7929	2.8083	2.8239	2.8397	2.8556	2.8716	2.8878	26	52	78	104	131
71	2.9042	2.9208	2.9375	2.9544	2.9714	2.9887	3.0061	3.0237	3.0415	3.0595	29	58	87	116	145
72	3.0777	3.0961	3.1146	3.1334	3.1524	3.1716	3.1910	3.2106	3.2305	3.2506	32	64	96	129	161
73	3.2709	3.2914	3.3122	3.3332	3.3544	3.3759	3.3977	3.4197	3.4420	3.4646	36	72	108	144	180
74	3.4874	3.5105	3.5339	3.5576	3.5816	3.6059	3.6305	3.6554	3.6806	3.7062	41	81	122	163	204
75	3.7321	3.7583	3.7848	3.8118	3.8391	3.8667	3.8947	3.9232	3.9520	3.9812	46	93	139	186	232
76	4.0108	4.0408	4.0713	4.1022	4.1335	4.1653	4.1976	4.2303	4.2635	4.2972	53	107	160	213	267
77	4.3315	4.3662	4.4015	4.4374	4.4737	4.5107	4.5483	4.5864	4.6252	4.6646					
78	4.7046	4.7453	4.7867	4.8288	4.8716	4.9152	4.9594	5.0045	5.0504	5.0970					
79	5.1446	5.1929	5.2422	5.2924	5.3435	5.3955	5.4486	5.5026	5.5578	5.6140					
80	5.6713	5.7297	5.7894	5.8502	5.9124	5.9758	6.0405	6.1066	6.1742	6.2432					
81	6.3138	6.3859	6.4596	6.5350	6.6122	6.6912	6.7720	6.8548	6.9395	7.0264					
82	7.1154	7.2066	7.3002	7.3962	7.4947	7.5958	7.6996	7.8062	7.9158	8.0285					
83	8.1443	8.2636	8.3863	8.5126	8.6427	8.7769	8.9152	9.0579	9.2052	9.3572					
84	9.5144	9.677	9.845	10.02	10.20	10.39	10.58	10.78	10.99	11.20					
85	11.43	11.66	11.91	12.16	12.43	12.71	13.00	13.30	13.62	13.95					
86	14.30	14.67	15.06	15.46	15.89	16.35	16.83	17.34	17.89	18.46					
87	19.08	19.74	20.45	21.20	22.02	22.90	23.86	24.90	26.03	27.27					
88	28.64	30.14	31.82	33.69	35.80	38.19	40.92	44.07	47.74	52.08					
89	57.29	63.66	71.62	81.85	95.49	114.6	143.2	191.0	286.5	573.0					
90	x														

DIFFERENCES  
UNTRUSTWORTHY  
HERE

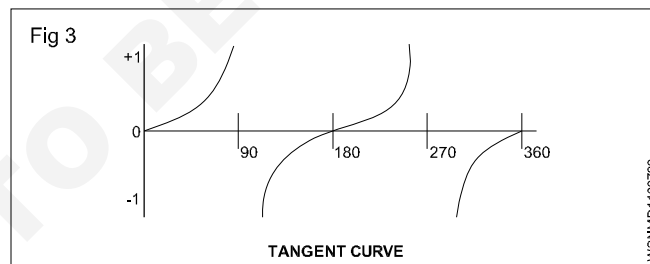

Quadrant	Angle	tan A =	Examples
First	0 to 90°	tan A	tan 56°17' = 1.4986
Second	90° to 180°	-tan(180° - A)	tan 123°43' = -tan(180° - 123°43') = -tan 56°17' = -1.4986
Third	180° to 270°	tan(A - 180°)	tan 236°17' = tan(236°17' - 180°) = tan 56°17' = 1.4986
Fourth	270° to 360°	-tan(360° - A)	tan 303°43' = -tan(360° - 303°43') = -tan 56°17' = -1.4986